

Intermate LAN FS3

*10/100 Mbit Ethernet Multi-Protocol Internal Print Server
for Kyocera-Mita FS and KM Printers and Digital Copiers*

Print Server Administration Manual

2nd Edition

Document kl-008-4 13 February 2002.

Replaces KL-008-2, 2nd edition of the *LAN FS3 10/100 Ethernet User's Guide* except for some of KL-008-2's information on printing from different environments and on the Host Print Options for SCS TN3270E on IBM Mainframe Hosts.

This guide applies to the following firmware versions/code levels and higher:

Boot code K91_1071. IPDS API-Code K65_1161.

LAN FS3 including Novell Netware IPX/SPX support Main code K92_1491 (last release)

LAN FS3 including IPP support Main code K92_2011 (first release)

Differences in the product-levels are explained in the text.

No part of this manual may be photocopied or reproduced in any way, except where noted, without the written consent of LCI Intermate A/S.

© Copyright LCI Intermate A/S 2001.

Kongevejen 194A
3460 Birkerød
Denmark
E-mail: support@intermate.com
Internet: www.intermate.com

Pease International Tradeport
222 International Drive, Suite #195
Portsmouth, NH 03801
E-mail: support@intermate-us.com
Internet: www.intermate.com

Notices

Disclaimer

LCI Intermate A/S makes no warranty of any kind with regard to the contents or use of this guide, and specifically disclaims any express or implied warranties on merchant ability or fitness for any particular purpose.

LCI Intermate A/S shall not be liable for errors contained herein or for incidental or consequential damages in connection with the performance or use of this product.

Information in this guide is liable to change without notice and does not represent a commitment on the part of LCI Intermate A/S.

Trademarks

Intermate is a registered trademark of LCI Intermate A/S.

AFP, AIX, AS/400, IBM, IPDS, LAN Server, OS/2, OS/400, Print Services Facility, PSF and *WIN-OS/2* are registered trademarks of International Business Machines Corporation.

HP Open View and *PCL* are registered trademarks of Hewlett-Packard Company.

Windows 95 / 98, Windows NT, Windows2000, and Windows XP are registered trademarks of Microsoft Corporation.

WinZip® is a registered trademark of Nico Mak Computing Inc.

Novell, NDS, NetWare and *NWAdmin* are registered trademarks of Novell, Inc.

Any other trademarks appearing in this guide are the property of their respective owners.

Table of Contents

Introduction

1. Introduction	12
1.1. Target Audience and Products	12
1.1.1. Target Audience	12
1.1.2. Print Servers and Component Codes Covered	12
1.2. Types of Documentation	13
1.2.1. Manuals and Guides	13
1.2.2. Other Types of Documentation	14
1.3. Conventions Used in the Manual and Guides	15
1.4. Topics in This Book	16
1.4.1. About Tools for Management and Configuration.....	16
1.4.2. About Initial Contact	17
1.4.3. About Configuring the “Basic” and “Permission” Sub-Groups.....	18
1.4.4. About Configuring Services and Host-Sessions.....	19
Key Concepts, including NDO and HPO.....	19
“Output”	20
“Input”.....	21
1.4.5. About Information and Monitoring Possibilities	22
1.4.6. About Upgrades and Maintenance.....	23
1.4.7. About the Appendices	24

Tools for Management and Configuration

2. HTTP (Browser).....	26
2.1. Prerequisites.....	26
2.2. How To Connect	26
2.3. Menu Items and Groups Before Login	27
2.4. Login with User Name and Password.....	28
2.5. Menu Items and Groups After Login	29
2.6. How to Change Settings on Configuration Pages	30
2.7. Activating New Values By Rebooting	31
2.8. Logout.....	31

3. Configuration Using a Telnet Client.....	32
3.1. Connecting.....	32
3.2. Menu Items and Settings	33
3.3. Activating New Values By Rebooting	34
4. The Intermate Management and Configuration Utility (IMCU).....	35
4.1. What the IMCU Is and How It Works	35
4.2. This Chapter Covers Installation and Basic Use	36
4.3. Installation of the Various Elements	37
4.4. Establishing a Server	37
4.5. How to Log In and Out.....	38
4.6. Device List / Available Agents	39
<i>Figure 1.IMCU Column Selection.</i>	39
<i>Figure 2.Device List</i>	40
4.7. Installing Agents	41
4.7.1. Remote Installation of an Agent from the <i>IMCU server</i>	41
4.7.2. Direct Installation of an Agent on a PC	42
4.7.3. Troubleshooting Agent Installation on a PC	42
4.7.4. Embedded Agent on the <i>Intermate LAN FS3</i>	42

Initial Contact

5. IP Assignments for Initial Contact	44
5.1. Introduction	44
5.2. Information Needed Before Starting	45
5.3. Method Overview	47
5.4. Assignment Using BOOTP	49
5.5. Assignment Using RARP	50
5.6. Assignment Using DHCP	51
5.7. Static IP Assignment Using “ARP and PING”	52
5.8. Static IP Assignment Using the IMCU	54
5.9. .Static IP Assignment Using the Front Panel.....	56

Configuring the “Basic” and “Permissions” Sub-Groups

6. [TCP/IP]	58
6.1. Mandatory IP-identifying information	58
6.1.1. Host Name	58
6.1.2. Syntax for IP Address, Subnet Mask, and Default Gateway	58
6.1.3. Enable DHCP, BOOTP, RARP—or none of these.....	58
6.2. Optional Settings	59
6.2.1. DNS Server for Look-Ups.....	59
6.2.2. WINS Server	59
7. [General]	60
7.1. Administrative Parameters.....	60
7.1.1. Model.....	60
7.1.2. SysAdmin contact.....	60
7.1.3. Device’s location	60
7.1.4. Device Name.....	60
7.2. System Target Printer.....	61
7.3. Enable Front Panel Messages (on System Target Printer)	62
8. [Network]	63
8.1. Media speed and duplex.....	63
8.2. Enable Local MAC Address.....	63
8.3. Local MAC Address	64
9. Configuring Permissions	65
9.1. [Password Change]	65
9.2. [License Key]	66
9.2.1. Ordering a key	66
9.2.2. License Key Entry	67

Configuring Print Services and Host-Sessions

10. Processing Facilities	69
10.1. Introduction	69
10.2. TCP/IP Sessions, Services and Host-Sessions	70
<i>Figure 3. Services</i>	<i>70</i>
<i>Figure 4. HPO: SCS TN5250E Host Sessions</i>	<i>71</i>
<i>Figure 5. HPO: SCS TN3270E Host Session</i>	<i>72</i>
<i>Figure 6. HPO: IPDS Host Session</i>	<i>73</i>
10.3. Physical Printers = Target Printers	74
10.3.1. Local Printer	74
10.3.2. Network Printers Using “NDO”	74
10.3.3. The “System Target Printer”	74
10.4. “Use Logical Printer”	75
10.5. Processing Layers	76
<i>Figure 7. Processing layers. Read from left to right.</i>	<i>76</i>
10.6. Logical Printers	77
10.6.1. PRO	77
10.6.2. The Configurable Logical Printers 1-8	77
10.7. Data Manipulation in the Logical Printer Layer	79
10.7.1. Examples of Logical Printer Definitions	79
<i>Figure 8. Mixed, complex environment but only one printer</i>	<i>80</i>
10.7.2. Processing Flows—Examples	81
<i>Figure 9. “PRO” (Logical Printer 0)</i>	<i>81</i>
<i>Figure 10. SCS TN3270 through “PRO” (Logical Printer 0)</i>	<i>82</i>
<i>Figure 11. “PR5” configured for string before and string after</i>	<i>83</i>
<i>Figure 12. 5250E through “PR2”.</i>	<i>83</i>
10.8. “Load Balancing Pools” (NDO only)	84
10.9. Working with NDO Load Balancing Pools and Data Manipulation	85
<i>Figure 13. Complex example: logical printer configurations</i>	<i>85</i>
<i>Figure 14. Simpler example: services and logical printers</i>	<i>86</i>

11. Network Destination Option.....	87
11.1.Requirements	87
11.1.1. Recommended Features for Network Target Printers.....	87
11.1.2. Configurations for Each “Network Printer #”	87
11.2.Hostname	88
11.3.Print Method	88
11.4.Raw Socket TCP Port.....	89
11.5.Printer LPR Queue Name.....	90
11.6.LPR Count Byte (MB)	90
12. [Logical Printers 1-8]	91
12.1.Introduction	91
12.2.Target Printer.....	92
12.3.Load Balancing Pool.....	93
Determining the order of values to enter.....	93
12.4.String Before and String After.....	95
<i>Figure 15.Maximum number of Encoded Bytes</i>	95
12.5.String Substitutions.....	96
13. [Substitution Strings]	97
13.1.“Input String #” and “Output String#”	97
13.2.Planning.....	98
14. Services in “Input Control”	99
14.1.Raw Socket	99
14.2.LPR Print Queues (LPD Protocol)	101
14.3.FTP Print	103
14.4.IPP Print (Internet Printing Protocol)	104

Management— Information and Monitoring Possibilities

15. Printed Information Available	106
15.1.Main Status Pages	106
15.2..Other Printouts in the “Actions” Group	107
15.3.“Help” > [Quick Guide]	107
16. Standard Monitoring Information	108
16.1.The “Status” Group on the HTTP Menu	108
16.2.“Status > Target Printer Info”	109
16.3.“Status > System Log”	110
16.4.Warnings and Error Messages	111
16.4.1. Messages requiring you to seek help from a point of purchase	111
16.4.2. Messages about things you can fix yourself	111
17. Configurable Monitoring Tools.....	112
17.1.[IMCU Agent]	112
17.2.[E-Mail Notification].....	113
18. Configure [SNMP]	114
18.1.Introduction and Pre-Requisites	114
18.2.Set Up a Connection With Your SNMP Tool	115
18.3.Edit “Variables”	118
18.4.Load and Edit “Options” (Parameters).....	119
18.5.Traps	122
<i>Figure 16.SNMP Printer Trap Numbers</i>	<i>122</i>
18.6.Using and Viewing Traps.....	126
19. The KPM Printer Utility (External Tool).....	128
19.1.Purposes and Limitations	128
19.2.Configuration Tips	129
<i>Figure 17.Main screen of the KPM program</i>	<i>129</i>
<i>Figure 18.KPM Settings dialog box</i>	<i>130</i>

20. Printer and Job Status via "Finger" (External Tool)	131
20.1.Purposes and Limitations	131
20.2.How to Use It	132

Upgrades and Maintenance

21. Upgrade Components	134
21.1.What and How	134
21.1.1. How to Get Upgrades	134
21.1.2. How to See Which Firmware is Currently Loaded.....	134
21.2.What the Firmware File Names Mean	135
21.2.1. Version-Naming System.....	135
21.2.2. Overview of Component Types and File Names.....	135
21.3."FSS-Files"	136
21.4.Configuration Files.....	137
21.4.1. "The" configuration file: ima_cfg.bin	137
21.4.2. .IDB	138
21.5.The Print Server's FTP Directory and Its Libraries	139
21.6.How to Inspect the FTP Directory.....	140
22. Using FTP Directly	141
22.1.Upgrades of Firmware and Fonts (FFS files)	141
22.2.Upgrades of IDBs	143
22.3.The Binary Configuration File (ima_config.bin)	144
23. Using the IMCU for Maintenance	146
23.1.Advantages.....	146
23.2.Single Print Server.....	147
23.3.Bulk Upgrade.....	152
24. Upgrade of Main Code or Boot Code Using a Serial Cable	154
24.1.The Cable	154
24.2.The Intermate Download Utility Program.....	155

25. Overview of Types of Resets	156
25.1. Activate New, Saved Settings with a Reboot	156
25.2. Restore Factory Default Settings: Remote	157
HTTP Menu: Configuration Page Only	157
HTTP Menu: "Restore All Defaults"	157
Telnet Client:	157
25.3. Restore Factory Defaults: TEST Button	158
General Information	158

Appendices

A. Customer Support	160
A.1. Where to Find Support	160
A.2. Gathering Information	160
B. Technical Information	161
B.1. Hardware	161
<i>Figure 19. What the Back Panel Looks Like</i>	<i>161</i>
B.2. Supported Printers and Performance Features	162
B.3. Emission Notices and Approvals	164
C. Hardware Installation	165
D. Information from LEDs and from the TEST Button	166
D.1. LED Patterns in Various Modes	166
D.2. TEST Button to Print Main Status Pages or Quick Guide	168
E. ASCII 7-bit Character Set: Decimal Values 32 - 126	169
F. String Syntax	171
F.1. Basic Rules and Encoded Bytes	171
F.2. Examples of Valid Strings and Invalid Strings	172
G. Configuration Checklists	173
G.1. Overall Checklist	173
G.2. Checklist for Each Service or Host Session	175

INTRODUCTION

1. Introduction

1.1. Target Audience and Products

1.1.1. Target Audience

You are a “printer administrator” with responsibility for configuring and administrating printers and print servers. You may also be a “network administrator”, and if not, you will sometimes need to talk with one.

The information in this manual does not cover special option settings intended for our partners. Please contact our support department if you need information about the special “OEM” settings.

1.1.2. Print Servers and Component Codes Covered

K92_1491

Main code level K92_1491 is the last release (from December 2001) supporting Novell NetWare IPX/SPX-based printing. Effective 4 January 2002, the LAN FS3 will not be sold with IPX/ SPX-based NetWare print support for Bindery and NDS modes. Due to license issues, down-grading an *Intermate LAN FS3* purchased after 4 January 2002 (K92_2011 and higher) will constitute a copyright violation.

Please note, however, that you can print through the *Intermate LAN FS3* from a NetWare platform based on pure IP, such as that in NetWare 5 (released in 1998). The combination of standard LPD and SNMP implementations in the print server will support the standard NDPS Gateway delivered with NetWare 5, thus providing a controlled bi-directional print method. Consult your NetWare documentation for help in setting up a printer; you will not need any special settings in the *Intermate LAN FS3*.

K92_2011

Main code level K92_2011 is the first release (from January 2002) supporting IPP.

1.2. Types of Documentation

1.2.1. Manuals and Guides

The set of Manuals and Guide provided on the CD—and updated on our web site— includes the Print Server Administration Manual (this book) and the Printing Environment Guides.

The ***Print Server Administration Manual*** tells you how to configure server-wide settings (with more information on IP-configuration than is provided in *Getting Started* or the *Quick Guide*), and how to configure the basic printing services: Raw Socket, LPR, FTP, and IPP. It also describes tools you can use for monitoring/managing, troubleshooting and maintenance.

The ***Printing Environment Guides*** give information on printing from different environments. Included in each guide are not only the details of special settings on your *Intermate LAN FS3*, but also information on how to configure the platform from which printing is to be done. In addition, troubleshooting for each particular environment is covered.

- In connection with each guide for IBM environments, there is the appropriate information for using the applicable Host Print Options (the HPOs), encompassing AFP/IPDS, SCS TN3270E, and SCS TN5250E). The *Printing Environment Guide for IBM OS/400 Systems* including the IPDS and SCS TN5250E HPOs is ready.
- We expect to have all the *Printing Environment Guides* on our web-site by the end of February, 2002. In the mean time, if you use the HPO for SCS TN3270E (IBM Mainframe Hosts), please consult the *LAN FS3 10/100 Ethernet User's Guide* (KL-008-2).

Note that *all* information on license keys, firmware upgrade and customer support is collected in the *Server Administration Guide*.

Please note the following restrictions on the HPOs:

- “IPDS Option”. If you enable and use this option without having a license key, each page will be overwritten with a “Demo/Test Mode” banner. IPDS printing is only available on monochrome printers with at least 12 MB RAM.
- “TN5250E Option”. If you enable this option and use it to print SCS jobs or jobs using Host Print Transform without having a license key, the last line on each printed page will be overwritten with a “demo mode” message.
- “TN3270E Option”. If you enable this option and use it to print SCS jobs without having a license key, the last line on each printed page will be overwritten with a “demo mode” message.

1.2.2. Other Types of Documentation

There are three types of documentation:

- **Product Overview** is a sheet included with the package. It lists what is in the package, including the contents of the CD-ROM and information on updates.
- **Getting Started** is a brochure included with the package, covering hardware installation, information on getting IP-connected and information on how to start printing from a Windows 2000 platform.
- **Quick Guide** is a mini-manual in text-format which can be printed directly from the print server. It is meant especially to rescue users who don't have anything else at hand.

All three types are also included on the CD-ROM and available on our web-site.

Because the *Intermate LAN FS3* integrates so deeply with your printer, you should always have access to **printer documentation**.

1.3. Conventions Used in the Manual and Guides

The notation used is based on what you see in the HTTP-based dialog for management and configuration.

This dialog has a left menu divided into group, sub-groups and items. When we refer to such groups, sub-groups or items, we use “double quotes” and connect the levels with a right angled bracket >.

“Configuration > Input Control > LPR” is an example of “Group > Sub-Group > Item”.

Many of the items open a configuration page. In descriptions of how to do the configuration, the name of a configuration page is put into [square brackets].

“Input Control” > [LPR] is an example of “Group” > [Configuration Page].

The individual fields and buttons on a configuration page are usually identified by putting the field name or button name in “double quotes” unless the meaning is clear enough that no special signs are needed.

<Expressions within angled brackets> are used in two contexts.

- <key on the keyboard>
- <parameter name> which is to be replaced by a specific parameter value when you do your settings

1.4. Topics in This Book

The rest of this book is divided into the following parts:

- Tools for Management and Configuration
- Initial Contact
- Configuring the “Basic” and “Permissions” Sub-Groups
- Configuring Services and Host-Sessions
- Information and Monitoring Possibilities
- Upgrades and Maintenance
- Appendices

Each part has several chapters. The following information should help you to determine which chapters you need to use and whether there are special pre-requisites you need to fulfill before proceeding.

1.4.1. About Tools for Management and Configuration

- [Chapter 2 “HTTP \(Browser\)” \(page 26\)](#)

The *Intermate LAN FS3* has an HTTP server in it which you attach to using a browser. Because the HTTP-based menu is the most comprehensive configuration tool, we use it as the framework for the whole manual. The HTTP-based menu also gives access to status information (described mainly in the chapters within “[Management— Information and Monitoring Possibilities](#)”, starting on [page 105](#)) and to “actions” not obtainable in any other way.
- [Chapter 3 “Configuration Using a Telnet Client” \(page 32\)](#)

If there are very strong reasons for not using a Windows-based configuration tool, you can use a Telnet client. The menu presented to a Telnet client is does not include status or actions (except for reboots), and the dialog is much more difficult to use than either the HTTP-based menu or the configuration tool presented in the following chapter.

- [Chapter 4 “The Intermate Management and Configuration Utility \(IMCU\)” \(page 35\)](#)

This chapter covers how to install and use this powerful Windows-based utility as a supplementary tool for configuration and management. As a tool for configuring a single unit, the *IMCU* is especially useful in establishing initial contact. Most users will find other tools more useful for configuring the other parameters and options.

The *IMCU* is also a monitoring tool that can give you an overview over many different kinds of network devices and their network status (such as “not available”, “sleeping”, ready); for printers, you can also see “page count”. These possibilities are also introduced in [Chapter 4](#), in the section [“Device List / Available Agents” \(page 39\)](#).

Finally, the *IMCU* can also be used for firmware upgrades and for copying configuration files from one unit to one or more other units (both in the chapters in [“Upgrades and Maintenance”](#), starting on [page 133](#), and in some of the appendices)

1.4.2. About Initial Contact

This part of the manual consists of one large chapter, [Chapter 5 “IP Assignments for Initial Contact” \(page 44\)](#).

It contains comprehensive information on how to choose a method for assigning TCP/IP-related information (IP address, subnet mask, default gateway and host name)—and how to use the chosen method. It is meant to help those whose situation cannot be easily handled with the information in *Getting Started* or the *Quick Guide*.

1.4.3. About Configuring the “Basic” and “Permission” Sub-Groups

The chapters in this part of the manual are organized according to configuration pages in the HTTP-based menu.

The HTTP-based menu is divided into four groups:

- Actions
- Configurations
- Status
- Help

Within the “Configurations” group on the menu, there are a number of sub-groups. Each sub-group has a number of configuration pages. Each chapter title in [Square Brackets] indicates a configuration page.

The order in which these pages are presented reflects a typical order for first time use. This may differ from the order on the HTTP menu, where the least frequently used pages are at the bottom of the “Configurations” group.

The “Basic” sub-group has three configuration pages

- “[TCP/IP]” (page 58)

Besides IP address, subnet mask, default gateway, and host name, the [TCP/IP] page allows you to specify a WINS server to which this information will be sent. It also allows you to register the IP address of a DNS server on which the unit can look up the addresses of named servers on other configuration pages.

- “[General]” (page 60)

This configuration page includes a number of purely administrative parameters: What will you call the device, who is responsible for it and where it is located?

It also includes a parameter to designate the “System Target Printer”, which is where information about the system is printed; and there is a parameter defining whether or not front panel messages should be enabled on that printer.

- “[Network]” (page 63)
This configuration page allows you to adjust “Speed / Duplex” (needed very rarely). In addition, it gives you the possibility of setting a “Local MAC address”.

The “Permissions” sub-group has two configuration pages

- “[Password Change]” (page 65)
- “[License Key]” (page 66)

1.4.4. About Configuring Services and Host-Sessions

Key Concepts, including NDO and HPO

The *Intermate LAN FS3* allows you to print over a LAN to a designated printer from a number of different environments, using your choice of protocol.

Input control. This is an umbrella term for protocols and printing methods. In connection with the IBM Host Print Options (HPOs), there are a great many possible settings. The HPOs are AFP/IPDS, SCS TN5250E and SCS TN3270E.

Target printer. This is the physical printer. It is possible to buy a license key for the Network Destination Option (NDO). This allows you to use just one intelligent multi-protocol print server not only to control jobs to the local printer (in which the *Intermate LAN FS3* is inserted) but also to send such jobs to up to four network destinations, where the printers are connected with inexpensive basic LAN network-cards. In addition, the NDO provides load-balancing among the network destinations.

Logical printer. This is a queue you can use in order to get pre- and post-job processing carried out, as well as defining string-substitutions within a job. A logical printer definition will always point to a target printer.

Mapping the use of a target printer to a given service always requires using a logical printer definition.

The information in the chapter on “*Processing Facilities*” (page 69) explains how all these things fit together. Some of the information may seem abstract until you have tried your hand

at configuring, so you will probably return to this chapter many times.

The rest of the chapters within “Configuring Services and Host-Session” are organized according to sub-groups of configuration pages in the HTTP-based menu. Each title in [Square Brackets] indicates a configuration page.

“Output”

Because each input must point to an output, it is often convenient to have output control configured before configuring input. Output has two dimensions—physical and logical. The “Output Control” sub-group has three pages, one for the physical dimension and two for the logical.

The Physical Dimension of Output: Target Printer(s)

- [“Network Destination Option” \(page 87\)](#)

Skip this chapter if you only intend to use a local printer.

This chapter tells you how to configure up to four network destinations. If you define and use a network destination without having a key, the print will be sent to the local printer.

The network destination configurations are only a small part of setting up your *Intermate LAN FS3* for NDO. The other things that need to be done are covered in the chapter on [“Processing Facilities” \(page 69\)](#)

The Logical Dimension of Output

The practical details of configuration are covered in

- [“\[Logical Printers 1-8\]” \(page 91\)](#)
- [“\[Substitution Strings\]” \(page 97\)](#).

The information needed to understand how these things work and how to use them is in the chapter on [“Processing Facilities” \(page 69\)](#).

“Input”

“Input” is the umbrella term for protocols and printing methods. The individual menu items for configuring input are found in the following five sub-groups on the browser menu:

- **“Input Control” Sub-Group**

“Services in “Input Control”” (page 99) covers the configuration of basic print services, which are protocol and methods requiring very little configuration: Raw Socket, LPR, FTP Print, and IPP.

You can create up to four different definitions for Raw Socket by defining different TCP ports, and you can define up to eight LPR queues. So in all, you can configure 14 services on these four configuration pages.

You must, of course, also establish printer definitions which can use these services. How to do this is covered in *Printing Environment Guides* (or equivalent sections in the *LAN FS3 10/100 Ethernet User’s Guide* (KL-008-2)).

- **“TN5250E Option” Sub-Group** is covered in the *Printing Environment Guide for IBM OS/400 Systems*.
- **“TN3270E Option” Sub-Group** is covered in the *Printing Environment Guide for IBM Mainframe Hosts* (or equivalent sections in the *LAN FS3 10/100 Ethernet User’s Guide* (KL-008-2)).
- **“IPDS Option” Sub-Group** is covered in *Printing Environment Guides* for four IBM environments (or equivalent sections in the *LAN FS3 10/100 Ethernet User’s Guide* (KL-008-2)). These environments are listed in this manual in *“TCP/IP Sessions, Services and Host-Sessions” (page 70)*.

- **“Novell Netware” Sub-Group**, for support of IPX/SPX-based printing in NDS and Bindery modes, is covered in a *Printing Environment Guide* published in December 2001.
This feature is only available on *Intermate LAN FS3s* sold before 4 January 2002, up to and including code level K92_1491.

1.4.5. About Information and Monitoring Possibilities

- [“Printed Information Available” \(page 106\)](#).
“Print Main Status Pages” is the most important item.
- [“Standard Monitoring Information” \(page 108\)](#) covers all of the “Status” information you can get printed to the screen. “System Log” is the most important item. Note that you can get a hard copy of the *System Log* by printing the *Main Status Pages*.
- [“Configurable Monitoring Tools” \(page 112\)](#) tells you
 - How to enable/ create an *IMCU* agent
 - How to enable and configure e-mail notification about what is happening with printer(s) served by any given *Intermate LAN FS3*.
- [“Configure \[SNMP\]” \(page 114\)](#) tells you how to enable and configure the *Intermate LAN FS3* so that you can use a fully featured SNMP-based network management tool (such as *HP OpenView*) to manage many printers and monitor their activity in detail.
- [“The KPM Printer Utility \(External Tool\)” \(page 128\)](#) gives tips on using this SNMP-based printer management tool from Kyocera-Mita.
- [“Printer and Job Status via “Finger” \(External Tool\)” \(page 131\)](#) tells you how to use the TCP/IP “Finger” command from a Windows management environment (NT or more advanced) or a UNIX/similar management environment.

1.4.6. About Upgrades and Maintenance

Chapters on upgrades and maintenance

Starting on page [page 134](#), this part of the manual tells you what kinds of things you can upgrade, explains the file-version naming- and numbering-system, and tells you how to proceed using three different methods. How to do bulk upgrades is also explained.

Maintenance-related items on the HTTP menu

The "Actions" group on the HTTP menu has three items dealing with maintenance:

- two kinds of reboots (for information on these, see [“Activating New Values By Rebooting” \(page 31\)](#))
- restoring “All defaults” (for information on this, see [“Overview of Types of Resets” \(page 156\)](#)).

The “Links” group has two items, both of which are meant to help you keep your software and documentation up to date:

- “Contact Information” = Start Page
- “Update/Utilities” = A direct link to a relevant web-site. If you want this opened in a new browser instance, hold down the <shift> key on your keyboard while clicking on the link.

1.4.7. About the Appendices

The Appendices include reference information which is useful in several different contexts:

- “Customer Support” (page 160)— where and how to get it.
- “Technical Information” (page 161), including emission notices.
- “Hardware Installation” (page 165)—included just in case you have lost the “Getting Started” brochure.
- “Information from LEDs and from the TEST Button” (page 166).
- “ASCII 7-bit Character Set: Decimal Values 32 - 126” (page 169)—these are the characters which are (almost) always sure to be printable; 33-122 are as good as 100% consistent in all kinds of code pages.
- “String Syntax” (page 171) for pre-processing, post-processing and string substitution.
- “Configuration Checklists” (page 173) for the whole configuration process and for the configuration of each single service or host-session.

TOOLS FOR MANAGEMENT AND CONFIGURATION

2. HTTP (Browser)

2.1. Prerequisites

The following description assumes that you have already assigned an IP address to the *Intermate LAN FS3*.

If the instructions in the brochure *Getting Started* or the on-board *Quick Guide* haven't met your needs, refer to [Chapter 6 "\[TCP/IP\]" \(page 58\)](#) where there are supplementary explanations and instructions for other methods.

You may have to set up an IP-route in order for the browser to be able to connect to the *Intermate LAN FS3*. If you are in doubt, ask your network administrator.

You need a browser which supports frame-sets and Java Script.

2.2. How To Connect

Type the IP address for the *Intermate LAN FS3* in the address field of the browser. For example:

```
http://192.168.0.227
```

The browser's Title Bar will show the print server name and brand followed by a hardware address in parentheses; the name of the browser usually concludes the information on the Title Bar.

The hardware address shown will be the global MAC address (as described in ["Hardware" \(page 161\)](#)) unless you choose to set a "local MAC Address" (as described in ["Enable Local MAC Address" \(page 63\)](#)).

2.3. Menu Items and Groups Before Login

The menu items are presented in the following four groups:

- Actions
- Status
- Help
- Links

“Actions”

In the starting menu, the only action listed is “login”. After your login, the content of “Actions” will change and a whole new group, “Configurations”, will be added.

The menu items in the next three groups remain constant and the groups remain placed at the bottom of the menu bar, so after login, you may need to scroll down to find them.

- “**Status**” includes several partial or specialized types of status which are displayed on screen. We will return to these in the chapter on Monitoring, starting with [“The “Status” Group on the HTTP Menu” \(page 108\)](#)
- “**Help**” includes one item, the *Quick Guide*.

The *Quick Guide* can alternatively be printed directly out from TEST Button by pressing it in when the unit is Ready (green LED is lit) and holding for more than 5 seconds.
- “**Links**” includes two items:
 - [Contact info] is the same information that is displayed when you attach to the print server, before you login.
 - [Updates/Utilities] hops to the product-web site from which you can download firmware upgrades, utilities, and updated documentation.

2.4. Login with User Name and Password

Choose “Actions > Login”.

Type in values for “User name” and “Password.” Both are case-sensitive.

If you are not a partner, there is only one possible “User name” (account), and this is `admin`.

The default password for the “admin” account is `admin`. It can be changed after a successful login.

Tip:

If the *Intermate LAN FS3* has been accessed before from the computer running the web browser, you should use the browser’s “Refresh” or equivalent button unless you are sure that the browser has been set not to use cached information

Tip:

If several different administrators and/or super-users are permitted to log on to the *Intermate LAN FS3*, it is possible that someone has changed the password and forgotten to tell you. So, if you are blocked after the first try, stop, and sort out who has changed the password before continuing.

2.5. Menu Items and Groups After Login

After a successful login, the “Actions” group with its single “Login” menu item will be replaced with two main groups of items:

- “Actions”
- “Configurations”—as listed in [“Topics in This Book” \(page 16\)](#)

“**Actions**” always give you the chance to “Cancel” or “Confirm” on an [<Action>] page before the system carries an action out. You can use “Actions” for the following things.

- Reboot There are two kinds of [Reboot], as explained below, in [“Activating New Values By Rebooting” \(page 31\)](#).
- “Print Main Status Pages”. These pages show configuration, i.e. all currently active settings for all parameters on the print server (except for certain configurations for the SCS HPOs).

In addition, the *Main Status Pages* include information from the *System Log* which is filled from reboot to reboot.

It is a good idea to document each configuration change by printing the *Main Status Pages*.

- Print several different kinds of status pages for 5250 (shown only if the TN5250E HPO is enabled).
- Stop traces started through an FTP session—depending on which options—TN5250E, TN3270 and/or IPDS, if any—have been activated.
- “Restore All Defaults.” This affects every single parameter, including identifying information, such as IP address, although some configurations for SCS HPOs are excepted.

2.6. How to Change Settings on Configuration Pages

When you choose a menu item for configuration, you will be presented with a page containing a number of parameters. In some cases, a configuration page can require scrolling down several screens. There are also some complex configurations which are presented as a sub-group of menu items, each with its own configuration page.

New settings for any given parameter are selected from a drop-down menu, selected by choosing a radio button, or typed into an input field. For many of the fields, you will find printed texts showing valid ranges. You may also find an “on-mouse-over”/“walk-over” description with additional information on the parameter in question.

You can save some mouse-clicks by using the <Tab> key to move from one parameter to another.

At the bottom of each configuration page are three buttons:

- **“Save & Cont.”** validates and saves the new settings. You can save a mouse-click by using the < Enter> key on your keyboard instead.

If you type an invalid value in an input field, the configuration page will be replaced with a page telling with the following message

“Error in input field '<parameter name>
Press the Browser’s Back Button”

When you do that, you will be presented with the configuration page again. You will probably have to look in the manual to correct your error.

- **“Undo”** restores the most recently saved settings. So if you have already saved your current work, you cannot use this button to move back to the previous values.
- **“Factory Default”** restores the default settings for the parameters on the configuration page in question—and only on that page.

Saved settings are not activated until you reboot; the next section explains how to do this.

If you are changing settings on more than one configuration page, it is usually a good idea to wait until you're done with everything before rebooting.

2.7. Activating New Values By Rebooting

New values can be activated remotely by clicking one of the two "Reboot" items in the Main Group "Actions".

- "**Reboot (immediate)**" reboots the *Intermate LAN FS3* immediately, terminating any current print job and. Jobs queued after a terminated job are not affected.
- "**Reboot (controlled)**" performs a delayed reboot. A reboot command is added to the job queue. The reboot is carried out when there are no more jobs known to the *Intermate LAN FS3*.

You can also reboot by re-cycling printer power. If you choose to do this, make sure that at least 10 seconds go by after the settings are saved **before** powering Off

2.8. Logout

Log out from the *Intermate LAN FS3* by closing the browser window.

Changing to another web address while running the same browser instance does **not** terminate the HTTP session.

3. Configuration Using a Telnet Client

3.1. Connecting

Platform Prerequisites

Any Telnet client supporting NVT can be used to connect to the *Intermate LAN FS3*. This includes common platforms like Windows, UNIX and AS/400.

NVT is a minimum requirement for the client. The *Intermate LAN FS3* defaults to NVT when connected with VT52 or VT100/ANSI.

Setting Up Telnet Terminal Preferences

We recommend enabling *Local Echo* on the client in order to display the entries. The *Buffer size* should also be checked, as some values otherwise can disappear from the screen. A value of 50 or more is recommended.

Logging On

A line-based Telnet client connects like this.

```
c:\telnet 192.168.4.170 (Windows example)
```

```
===>telnet '192.168.4.170' (AS/400 example)
```

When a Telnet session is started, the *Intermate LAN FS3* presents itself with the log-on screen.

Type the *user* name: `admin` followed by <CR/Enter>.

Type the *password* followed by <CR/Enter>. The default password is `admin`. (You can change this from the menu, “Password”. The password is case-sensitive).

Once you are logged in, the “Main Menu” appears.

You will be able to set everything except IP-address, Host-name and license keys—but, as mentioned in the introduction to this guide, it is clumsy to use.

3.2. Menu Items and Settings

“Main Menu”

For the most part, each item corresponds to a configuration page in the HTTP interface. For example:

1. General
2. Network.

...

The list ends with a display of the syntax for two kinds of save (S and C) and for exiting the Telnet session (Q). There is a timeout function that breaks the connection to the *Intermate LAN FS3* after about a minute of inactivity.

As indicated above, each item is numbered.

Select an item by typing the number of the item to the prompt > and pressing the <Enter> key.

Configuration Menus

When you have chosen an item on the main menu, you will be presented with a sub-menu with a heading, a numbered list of parameters and the message “R. Return to main menu”.

Examples of parameters in the sub-menu called “Raw Socket Menu”:

1. TCP Port 1 <9100>
2. Use Logical Printer 1 <PR0>
3. TCP Port 2 <9100>
4. Use Logical Printer 2 <PR4>

...

As you can see in the example above, each parameter line finishes by showing the current setting in angled brackets.

Select the parameter you want to change by typing in the number and pressing the <Enter> key.

You will then be shown the name of the parameter, the current setting, and information on possible values which are either chosen by item numbers or typed in. Pressing the <Enter> key finishes your data entry and returns you to the sub-menu (“previous menu”).

The sub-menu will show that you can use `p` (followed by `<Enter>`) to return to the previous menu, but sometimes entering `p` without first having entered a value can result in an error.

You can, however, always enter `r` (followed by `<Enter>`) to return to the Main Menu directly from the list of parameters on a configuration menu.

If the number of items does not fit on the screen, the text string `Press <Return>` is added to the default prompt. This means that `<Enter>` has to be pressed to view the next screen of items.

3.3. Activating New Values By Rebooting

New settings are saved and activated by selecting one of the two possible reboots.

Note:

In the commands below, “interface” means the *Intermate LAN FS3* print server

- "S. Save changes and reboot interface (immediate)" terminates any current print job and reboots the *Intermate LAN FS3* immediately. Jobs queued after a terminated job are not affected.
- The *C. Save changes and reboot interface (controlled)*. This performs a delayed reboot. A reboot command is added to the job queue. The reboot is carried out when there are no more jobs known to the *Intermate LAN FS3*.

4. The Intermate Management and Configuration Utility (IMCU)

4.1. What the *IMCU* Is and How It Works

The *Intermate Management and Configuration Utility (IMCU)* is a web server based tool for detection, monitoring and configuration of *Intermate* LAN devices in IP networks.

The system consists of an HTTP-based Windows NT service, with software agents distributed across the network to communicate with print servers on each physical LAN.

Management, installation of printers, installation and administration of agents are all done from a Web-browser. This means that you can administer printers locally from the *IMCU* server - or from another network-attached PC - or even from a remote connection via the Internet. Thus, it is possible for the system, network or printer administrator to gain access to all printers from his or her home office.

The agents detect devices using UDP, which means even print servers with no IP addresses can be monitored and configured. This approach enables a network/printer administrator to configure devices with mis- or unconfigured IP settings anywhere in the network, using a standard web browser. This is why it can be used for the initial assignment of an IP address as described in the *Getting Started* brochure, the *Quick Guide* and the section on [“Static IP Assignment Using the IMCU” \(page 54\)](#) in this book.

Limited SNMP support is available for the detecting and monitoring third party or legacy Intermate print servers.

The *IMCU* is free. An installation file (*P19-xxxx.EXE*) is included on the *Documentation and Utilities* CD. New versions of the utility will be made available on our web site.

4.2. This Chapter Covers Installation and Basic Use

This chapter presents only how to install the *IMCU* and lists the kind of information you can monitor with it.

Special uses of the *IMCU* are presented in other places in the documentation, directly in connection with the specific contexts in which it can be used. These uses are as follows:

- Configuration:
 - Initial contact as explained in [“Static IP Assignment Using the IMCU”](#) (page 54).
 - Upgrading firmware, fonts and special configuration files (see [“Upgrade Components”](#) (page 134) and [“Using the IMCU for Maintenance”](#) (page 146)).
- Management and editing of IDB (configuration) files for TN5250E. This feature was added (in beta) in P19_1491 (released 14 December 2001). See the *Printing Environment Guide for IBM OS/400 Systems*.

4.3. Installation of the Various Elements

The **IMCU server** installs on *Windows95/98/NT4.0/2000/XP* as a service where it detects, monitors and upgrades print servers in large segmented IP networks. Note that TCP/IP must be installed. You can configure the kind of information you want displayed.

An **agent** must be installed on a host on each IP segment having devices you wish to monitor through the *MCU* server. An agent can reside on either a PC or on an *Intermate LAN FS3* print server.

Each *Intermate LAN FS3* print server contains an **IMCU client** through which the agent can detect and configure first time IP settings, upgrade firmware and link to the print server's own Web page.

4.4. Establishing a Server

Remember that you must be logged on to the computer with a Windows NT account with administrative rights if you will be installing on Windows NT, Windows 2000 or Windows XP.

The *IMCU server program* is installed by copying the installation program to a PC running Windows and executing it. This installs the program files and starts the *IMCU service*.

The installation program will give you the possibility of installing a server, an agent, or both. It is a good idea to choose both, especially if the machine is on the segment where you will be installing the *Intermate LAN FS3*, because you will then be sure to have an agent that can detect the unit.

During server installation, the program asks for a port number for the server (default is 80). Change the port number if another service already uses it.

Tip:

You can check to see the ports your pc is listening to by using the command `netstat -an`.

Agent installation: Unless you have a very good reason for doing so, do not change the default port for the agent (8888).

4.5. How to Log In and Out

Log in:

Type the *IP address* of the PC running the server program in the address field of the web browser.

Example—when the *IMCU server* is not on your own work station.

`http://192.168.0.38` (default port)

`http://192.168.0.38:81` (alternative port)

If the *IMCU server* is on your own work station, use the loop-back IP:

`http://127.0.0.1` (default port)

`http://127.0.0.1:81` (alternative port)

When you are attached, you will be presented with the login dialog. There is only one possible *user name*: `imcu`. The default *password* is `imcu`, but it may have been changed by whoever it was that installed the *IMCU server*, so check with them. The password is case-sensitive.

Log out from the *IMCU server* by closing the browser window.

Changing to another web address while running the same browser instance does **not** terminate the HTTP session.

4.6. Device List / Available Agents

The device list is your entry way to using the *IMCU* server.

The screen is selected by clicking the "Device list" button in the top toolbar. You will be presented with a two column list showing "Agent" and "Devices", however the "Devices" will be empty.



Use the "Expand" icon to bring forth a list of the devices discovered on that segment.



Before proceeding to use the information on the list, use the "Refresh" icon to refresh the list; the browser's "refresh" is not good enough.

The "column selection" button, allows you to tailor the device list to your wishes.



































Figure 1. IMCU Column Selection.

- Status
- Name
- Location
- Description
- Printer type
- Printer firmware
- Printer serial no.
- Page count
- Interface type
- Interface firmware
- MAC address
- IP address
- Subnet mask
- Gateway
- Boot method
- Flags
- SNMP OID
- Links
- Agent

A sample device list is shown on the next page.

Figure 2. Device List

Agent	Devices							
2.1 net on DIK2   	Status	Name	Printer type	Interface type	Interface firmware	MAC address	IP address	Links
	Sleeping	kdc101test	LASERJET 4000	Intermate101	G32_2041	00c0a2008287	222.5.4.201	  
	Ready		[Unavailable]	Intermate101	G32_2041	00c0a2008285	222.5.4.165	  
	Ready	LANFS3_testafd	FS-3800	Intermate LAN FS3 10/100	K92_2011/K65_0441	00c0a2008280	222.5.4.202	  
IMPRINT SERVER 2.1 and 2.2   	Status	Name	Printer type	Interface type	Interface firmware	MAC address	IP address	Links
	Idle	Print Server	Not Available	Intermate100 Print Server	G22_1491	00c0a200f3c6	222.2.1.207	  
	Ready	LXK193FA6	Lexmark T620	MarkNet N2001e	3.17.4	00040098fc65	222.2.1.252	 
	Ready		[Unavailable]	Intermate101	G32_2041	00c0a2058127	222.2.2.223	  
	Ready	NB03148A	FS-5900C	SEH	8.2.124	00c0eb03148a	222.2.1.239	
	Sleeping	IC01DEA6	FS-7000	SEH	8.2.146	00c0eb01dea6	222.2.2.204	
	Sleeping	IC01DE9D	FS-7000	SEH	8.2.146	00c0eb01de9d	222.2.1.238	
	Sleeping	NB01A896	FS-7000	SEH	8.2.72	00c0eb01a896	222.2.2.205	
	Sleeping	NB01A889	FS-7000	SEH	8.2.72	00c0eb01a889	222.2.2.221	
	Sleeping	IC01DEAB	FS-7000	SEH	8.2.76	00c0eb01deab	222.2.2.215	
	Ready	Phaser 780	Phaser 780N	Tektronix	2.76/10.36/4.1.38/3.2	0800110ad601	222.2.2.112	
	ENERGIBESPARELSE		HP LaserJet 5Si	JetDirect J2552B	A.05.05	0060b01d651e	222.2.2.239	
	Ready	Phaser 740	Phaser 740P	Tektronix	4.08/8.62/17/1.24	08001100a02b	222.2.2.200	

4.7. Installing Agents

If there is an agent on the segment where your *Intermate LAN FS3* is placed, you are ready to use the *IMCU*.

If you do not know whether someone in your network environment has already established an agent on the segment where your *Intermate LAN FS3* is placed, log in to the *IMCU server* and use the Device List as described in the previous section. If the MAC address for your *Intermate LAN FS3* does not show up on any of the agents, you need to install one.

Unless you have a very good reason for doing so, do not change the default port for the agent (8888).

Note that it is possible to have several agents installed on the same physical network segment, but only one agent per host. The agent can be hosted on a pc or on an Intermate print server.

4.7.1. Remote Installation of an Agent from the *IMCU server*

If both the *IMCU server* and the pc which is to host the agent are running NT 4.0 or higher (Windows 2000, Windows XP), you can install an agent remotely.



Select Agent Management

Select "New". Fill out the necessary information and then select "Install". The necessary information is:

- "IP address" of the pc to host the agent.
- "Agent Name" (unless you are satisfied with the host IP address as the agent name). Try to choose a name which is meaningful for your administration.
- The "Port" contains the port number the agent uses for communication with the *IMCU server*. Default is 8888. Do not change this without a very good reason.
- You will probably not want to change the refresh or timeout intervals; check the on-line help if you are in doubt

After you select Install, you will be asked to enter a Windows NT account with administrative rights on the pc. You must enter Domain, Username, and Password. Click Install again.

4.7.2. Direct Installation of an Agent on a PC

If your setup does not fulfill the system requirement for remote installation, you will have to install an *IMCU* agent directly on a pc on the desired segment, for example your own work station. Perform this installation with the *IMCU* Installation Program, choosing "Agent Only".

Afterwards, return to the *IMCU* server.



Select Agent Management

Select "New". Fill out the necessary information and then select "Install". The necessary information is:

- "IP address" of the pc to host the agent.
- "Agent Name" (unless you are satisfied with the host IP address as the agent name). Try to choose a name which is meaningful for your administration.
- The "Port" contains the port number the agent uses for communication with the *IMCU server*. Default is 8888. Do not change this without a very good reason.
- You will probably not want to change the refresh or timeout intervals; check the on-line help if you are in doubt

Finish by selecting "Add" (instead of "Install").

4.7.3. Troubleshooting Agent Installation on a PC

If the agent was not created, click the browser's "back" button and check the information typed in. A typical problem is the *IP Address*. If the address cannot be reached, it may be because an IP route needs to be set up. Other common mistakes are misspelling of the *Domain*, *Username* or *Password*. Ask your system administrator for further details. The *IMCU server* has quite a lot of on-line help available.

4.7.4. Embedded Agent on the *Intermate LAN FS3*

If you already have given an *Intermate LAN FS3* (or another Intermate print server) an IP address using another method, you can activate the embedded agent on it. See "[[IMCU Agent](#)]" ([page 112](#)).

INITIAL CONTACT

5. IP Assignments for Initial Contact

5.1. Introduction

You must change the *IP address* from the factory default (0.0.0.0). Additional IP settings that may need configuration are the *Subnet Mask* (default 255.255.255.0) and the *Gateway* address (default 0.0.0.0). Note that the *Intermate LAN FS3* supports classless routing.

The methods available for setting the IP address vary depending on how your LAN environment is administered. When we discuss choosing a method, we are talking about the administration, and **not** the print platforms you will be using.

In fact, some of these platforms, notably IBM Mainframes (such as S/390) and Mid-Range (such as AS/400) have no management facilities of this type. This is no cause for concern. Most LANs are administered from a Windows work station, an OS/2 work station or a work station running UNIX, AIX or Novell Netware.

5.2. Information Needed Before Starting

If you haven't already done so, you must have the following information from (or cleared by) your **network administrator**:

- * IP address - in the examples we will use 192.168.0.227
(DHCP: You need a temporary static address)
- * Network Mask - in the examples we will use 255.255.255.0
(DHCP: Not necessary)
- * Default Gateway (unless Auto-Routing (RIP) is used).
(DHCP: Not necessary)

You also need to know the **MAC** address (= IEEE address = hardware adapter address) address of the unit. You can find the MAC address on the Main Status Pages. In the examples, we will use 00c0a200801e.

Host Name:

You must choose a host name which will identify the unit in the LAN environment. The unit will generate a default host name by attaching the last six digits from the MAC address to a prefix (lanfs3).

You may use, modify, or totally replace this name. If you use the following guidelines, you will avoid conflicts caused by differing protocols found in today's typically mixed network environments:

- Name length: minimum 2 and maximum 16 ASCII characters from the restricted list below.
- Do not use any tabs or character spaces ("blanks")
- There is no distinction made between upper and lower case.
- You can make the name DNS qualified by adding a company domain name and a top domain, for example im00801e.mycompany.com.
- Permissible characters: alpha (A-Z), numeric (digits 0-9), minus sign (-), underscore (_) and period (.)—subject to the following additional restrictions:

- Periods are only allowed when they serve to delimit components of DNS qualified names (“domain style names”).
- The first character must be alpha.
- The last character must not be a minus sign, an underscore or a period.

Finally, **if you will be using a method for initial contact which does not work across routers** you must do the following:

Find the *IP address* for your the PC or terminal from which you will be configuring the *Intermate LAN FS3*.

Tip:

DOS commands for *Windows* users
winipcfg (*Windows 95/98*) or
ipconfig (*Windows NT 4.0, Windows 2000* or *XP*)

Determine whether or not your PC's or terminal's IP address is on the same net-segment as the address chosen for the *Intermate LAN FS3*.

If there is a router or a gateway between the two, then you must get them both on the same segment or choose a method for assigning an address to the unit which can work across a router with the help of an IP static route.

How to find the group of settings called [TCP/IP]:

- Browser user: [TCP/IP] is in the "Basic" sub-group of the "Configurations" group.
- Telnet user: TCP/IP is a point on the main menu.

5.3. Method Overview

- Delivery from a BOOTP server. Management environments: Novell Netware, AIX, UNIX, AIX, OS/2. Instructions for using BOOTP start on page [49](#).
- Delivery from an RARP server. Management environments: UNIX only. Instructions start on page [50](#). The RARP daemon does not work across routers or gateways.
- Dynamic delivery from a DHCP server. This is mainly used to deliver IP addresses to PCs and work-stations, rather than to servers, but can be used to deliver an IP address to a print server such as the *Intermate LAN FS3*.

If you are required by your network administration to let a DHCP server assign an address to the unit, you will need to use a static assignment method (see below) to make initial contact with it, and then enable DHCP afterwards. Instructions start on page [51](#).

- Static Assignment. Four methods are available for this:
 - “ARP and PING” can be used in any of the LAN management environments mentioned, but should not be used if your system administrator requires the use of a BOOTP server or an RARP server. Instructions start on page [52](#). ARP does not work across routers or gateways.
 - The *Intermate Management and Configuration Utility (IMCU)* can be used in environments running under a Windows operating system (Windows 95/98, NT 4.0, Windows 2000). Instructions start on page [54](#).

Because the *IMCU* detects network devices at the hardware level you can set an IP address for a segment unreachable from your work station (as long as there is an agent on your own segment), do all or most of your configurations, and then move the *Intermate LAN FS3* to the segment containing that IP address. For

information on how to install the (IMCU), see [“The Intermate Management and Configuration Utility \(IMCU\)”](#) (page 35).

- Using the printer’s front panel display, if there is one.
- Addresses can be typed in to the input fields in the “Configuration [TCP/IP]” page. For obvious reasons, this cannot be used to establish initial contact with the print server

As default in the *Intermate LAN FS3*, RARP and BOOTP are enabled while DHCP is disabled. It is a good idea to make sure that only the method you use is enabled, while all other possibilities are disabled, because the unit uses a fixed boot-sequence.

The order of look up is DHCP, BOOTP, and RARP. There will be a time-out in connection with each unsuccessful wait to be contacted by a server of IP addresses.

After finding that there is no RARP server on the network, the unit will then check the current IP address. If it is 0.0.0.0, the system will wait for an ARP/PING mapping its MAC address to an IP address. If the current IP address is different from 0.0.0.0, the system will use whatever address is stored currently.

When you are finished establishing contact as explained below, you can continue with your configurations following the order of the chapters in this book. It is often a good idea to print the *Main Status Pages* to document your configurations.

5.4. Assignment Using BOOTP

- 1 Connect the printer to the LAN and power it On.
- 2 Alter the [`/etc/bootptab`] file on the host. If this file does not exist on your system, it must be created manually using an ASCII file editor. Insert the following sequence in the [`/etc/bootptab`] file:

Syntax (written on a single line; it will rarely be possible to write the whole string on a single line, and you can usually use backslash at the end of each line to indicate that the definition continues)

```
<host name>: ht=<hardware type>: ha=<hardware
address>: hn: ip=<IP address>: sm=<subnet mask>:
gw=<gateway field>
```

Example:

```
lanfs300801e: ht=ether: ha=00c0a200801e: hn: \
ip=192.168.0.227: sm=255.255.255.0: gw=192.168.0.1
```

- 3 Save the [`/etc/bootptab`] file.

Note:

On platforms other than OS/2, you may need to reinitialize the BOOTP-server every time you make changes to the [`/etc/bootptab`] file in order to be sure the changes take immediate effect.

For the AIX platform, however, it is sufficient to refresh the *inetd* subsystem. Syntax:

```
refresh -s inetd
```

- 4 Connect and Login to the unit with a browser or Telnet client.
- 5 Choose [TCP/IP].
- 6 Disable RARP and check to be sure that DHCP is still disabled.
Note that the BOOTP delivers not only the IP address, but also the subnet mask and the default gateway.
- 7 Save your work and reboot. You can, of course, wait to reboot until finishing other configurations you want to make.

5.5. Assignment Using RARP

- 1 Connect the printer to the LAN and power it On.
- 2 Add the following lines to the [*/etc/ethers*] file or [*/etc/rarpd.cf*] file: Note that the MAC address is written with colons : as separators between every two characters.
 - [*/etc/ethers*] file
 - <Hardware address> <Host name> (syntax)
 - 00:c0:a2:00:80:1e fs3-a (example)
 - Or
 - [*/etc/rarpd.cf*] file
 - <IP address> <Hardware address> (syntax)
 - 192.168.0.227 00:c0:a2:00:80:1e (example)
- a Update your host table and alias name data bases.
- b Start the RARP daemon, if it is not already running.
 - rarpd -a
- 3 Connect and Login to the unit with the tool of your choice.
- 4 Choose [TCP/IP].
 - a Disable BOOTP and check to be sure that DHCP is still disabled.
 - b If it is not possible for *Intermate LAN FS3* to obtain the mask from the network, you must type in a Subnet Mask.
 - c If automatic routing (RIP) is not used in your environment, type in the Default Gateway.
- 5 Save your work and reboot. You can, of course, wait to reboot until finishing other configurations you want to make.

5.6. Assignment Using DHCP

DHCP can usually be enabled (“On”) via the printer's front panel display. If you prefer to enable DHCP remotely, follow the instructions below.

- 1 You must first assign an address statically using ARP and PING or the *IMCU*, as described in one of the sections below. When you continue from there, do the following:
- 2 Connect and Login to the unit with the tool of your choice.
- 3 Choose [TCP/IP].
 - a Disable BOOTP and RARP. Enable DHCP.
 - b If it is not possible for *Intermate LAN FS3* to obtain the mask from the network, you must type in a Subnet Mask.
 - c If automatic routing (RIP) is not used in your environment, type in the Default Gateway.
- 4 Save your work and reboot. You can, of course, wait to reboot until finishing other configurations you want to make.

5.7. Static IP Assignment Using “ARP and PING”

- 1 Make sure that you own PC or terminal is on the same network segment as planned for the *Intermate LAN FS3*.
- 2 Power the printer On.
- 3 Check the *Main Status Pages* to find the current IP address for your *Intermate LAN FS3*. You can print them by pressing the TEST Button for 2-3 seconds.

If the unit has already been assigned an IP address different from 0.0.0.0, you must re-set it in order to use the ARP command. For instructions, see “[Restore Factory Defaults: TEST Button](#)” (page 158).

- 4 Insert the relationship between the *IP address* and the *hardware adapter (MAC) address* in the ARP cache. The syntax varies according to your system environment. The examples below use the sample *IP address* 192.168.0.227.

From Windows environments

```
arp -s 192.168.0.227 00-c0-a2-00-80-1e
```

Tip:

Windows 95 does not add an entry in the ARP table if it is empty. So, if your ARP command doesn't work, ping in another IP device in the network and then enter the ARP command again

From UNIX, AIX, OS/2

```
arp -s 192.168.0.227 00:c0:a2:00:80:1e
```

Tip:

If you wish to assign a host name to the *Intermate LAN FS3*, you can insert the relationship between the IP address and the host name in your system host table. For example: 192.168.0.227 fs3-a

Then the host name can be used instead of the IP address in the ARP command above.

- 5 Ping the new *IP address* to store the address. Example:
`ping 192.168.0.227`
- 6 Pinging causes the *Intermate LAN FS3* to reboot automatically. Wait for the reboot to finish.
- 7 Connect and Login to the unit with the tool of your choice
 - a Choose [TCP/IP]
 - b Check to see that the BOOTP and RARP protocols are disabled (this should happen automatically when you use the ARP-PING method).
 - c If you will be only using the IP address as a stepping stone to DHCP, enable DHCP.

Otherwise, set the *Subnet Mask* and the *Gateway* (if auto-routing (RIP) is used, you can leave the Gateway as 0.0.0.0)

- 8 Save your work and reboot. You can, of course, wait to reboot until finishing other configurations you want to make.

5.8. Static IP Assignment Using the *IMCU*

Prerequisites

See [“The Intermate Management and Configuration Utility \(IMCU\)” \(page 35\)](#) for information on how to acquire, install and use this free utility program.

If your working place already uses the *IMCU*, check to be sure that the following things are in place.

- Find out what the *IMCU* server’s *IP address* is as well as what its *port number* has been set to (default is 80, but a network administrator or another printer administrator might have changed this to avoid colliding with another service).
- The server must be running; you may have to ask another administrator or super-user about this.
- There must be an agent enabled on the net segment your *Intermate LAN FS3* is connected to. If you are unsure about this, please consult [“Installing Agents” \(page 41\)](#).

Steps

- 1 Connect the printer to the LAN and power it On.
- 2 Log in to the *IMCU* server with a web browser (as instructed in [“How to Log In and Out” \(page 38\)](#)).
- 3 Use the “Device List” screen to find the agents known to the server.
- 4 Select and expand the agent monitoring the IP segment the *Intermate LAN FS3* is. This will give you a list of all the devices detected by the agent.
- 5 Refresh the list. If everything is as it should be, you should find a line for a device showing the MAC address for your *Intermate LAN FS3*. Double-click the MAC address.
- 6 This will open a “Device Configuration” window with the following fields:

- MAC Address
 - Name (= Host Name - not changeable from within the *IMCU*; see instructions in “Host Name” (page 58))
 - Six settable parameters from the “TCP/IP” sub-group: three fields to fill out (IP Address; Subnet mask; Gateway) and three check-box fields: RARP, BOOTP and DHCP.
- 7 Fill out the fields:
 - a IP address.
 - b If it is not possible for *Intermate LAN FS3* to obtain the mask from the network, you must type in a Subnet Mask.
 - c If automatic routing (RIP) is not used in your environment, type in the Default Gateway.
 - 8 Make sure the BOOTP and RARP protocols are disabled (unchecked).
 - 9 If you will be only using the IP address as a stepping stone to DHCP, enable DHCP.
 - 10 Conclude your work by clicking “Save and reboot”. You will receive a confirmation message.

If you will be continuing your configuration without delay, you have two choices.

Return to the “Device List” using the browser’s “back” button or the “Device List” icon. Find your *Intermate LAN FS3* and double-click on the “IP address” instead of the “MAC address”. This will open a new browser instance attached to the *Intermate LAN FS3*. Log in from there. This is usually the best choice.

The alternative is to actually use the *IMCU* as a complete configuration tool. Choose “Advanced” from the “Device Configuration” window. The resulting screen (after a login) contains links to all configuration pages, but the menu points have no grouping. And there are no links to status or action pages, help or contacts. This method should probably only be used if you have a lot of experience configuring the *Intermate LAN FS3*.

5.9. .Static IP Assignment Using the Front Panel

Layouts of the keys on the printer vary. Consult your printer's documentation for information on how to work the keys on the printer. The following instructions are meant to keep you from making serious errors.

- 1 Make sure the printer with the LAN FS3 is disconnected from the LAN.
- 2 Power On the printer.
- 3 Using the keys on the printer, enter configuration mode.
- 4 When you are finished setting the IP address, subnet mask and default gateway, be sure to save your work.
- 5 Wait at least 10 seconds, and then power the printer Off.
- 6 Reconnect the printer to the LAN by inserting the LAN drop cable into the LAN FS3. to the LAN.
- 7 Power the printer on.
- 8 You may want to confirm the results by printing a printer status page or a LANFS3 main status pages— press the TEST Button for 2-3 seconds after the Ready signal (green LED lit).

CONFIGURING THE “BASIC” AND “PERMISSIONS” SUB-GROUPS

6. [TCP/IP]

This chapter tells you about the individual parameters within the [TCP/IP] Configurations sub-group. This item is at the bottom of the “Configuration > Basic” sub-group, but should be done before continuing with other configurations. Details on IP-identifying Information are in [“IP Assignments for Initial Contact” \(page 44\)](#).

6.1. Mandatory IP-identifying information

6.1.1. Host Name

The host name identifies the unit in the LAN environment. You may use, modify, or totally replace the default host name which will be generated by attaching the last six digits from the MAC address to a prefix such as IM or IMA (depending on the product and model).

See the syntactical requirements for an IP host name in [“Information Needed Before Starting” \(page 45\)](#)

6.1.2. Syntax for IP Address, Subnet Mask, and Default Gateway

Default for each of these three parameters is 0.0.0.0

Syntax: Four address bytes separated by periods.

Each address byte must be a number between 0 and 255; do not use leading zeros. Not all combinations of values will constitute a valid address. Ask your system administrator if in doubt.

If Auto Routing (RIP) is used in your environment, you can leave the Default Gateway set to 0.0.0.0.

6.1.3. Enable DHCP, BOOTP, RARP—or none of these

Please consult the instructions in [“IP Assignments for Initial Contact” \(page 44\)](#).

6.2. Optional Settings

6.2.1. DNS Server for Look-Ups

There are a number of configurations in which you can either use a name or an IP, for example to register a mail server, a TN5250E server, or network printers.

If you want to use names, make sure that they can be looked up on a DNS server, and enter the IP of this DNS server here.

Syntax: Four address bytes separated by periods.

Each address byte must be a number in the interval [0..255]. Do not use leading zeros. Default is 0.0.0.0

6.2.2. WINS Server

If you enter WINS Server address, the contents of Hostname and IP Address for the unit are sent to the WINS server at start up.

Syntax: Four address bytes separated by periods.

Each address byte must be a number between 0 and 255. Do not use leading zeros. Default is 0.0.0.0

7. [General]

Each section in this chapter discusses a single parameter on the [General] configuration page in the “Configurations > Basic” sub-group. In order to aid understanding, the parameters are presented in a slightly different order than the order on the configuration page.

7.1. Administrative Parameters

7.1.1. Model

The [General] page leads in by displaying the print server’s model. This text cannot be edited through the usual menu; OEM partners, please contact our support department.

7.1.2. SysAdmin contact

Maximum 47 ASCII characters within the decimal range 32-126 (see the table on [page 169](#)). Use this parameter to indicate a contact person or department for local support and troubleshooting for the *Intermate LAN FS3*. The contact name will be printed on E-mail and SNMP notifications, should you implement them.

7.1.3. Device’s location

Maximum 47 ASCII characters within the decimal range 32-126 (see the table on [page 169](#)). Use this parameter to specify the physical location of the printer in which the *Intermate LAN FS3* is installed.

The device location will be printed on e-mail notifications, should you implement them.

7.1.4. Device Name

Maximum 47 ASCII characters within the decimal range 32-126 (see the table on [page 169](#)).

The device name will be printed on e-mail notifications, should you implement them.

Important:

Do not confuse this name with the Host Name (see [“Prerequisites” \(page 54\)](#) and [“Host Name” \(page 58\)](#)).

7.2. System Target Printer

The System Target Printer has the following special functions.

- When you choose “Actions” > [Print Main Status Pages] the output is directed to the System Target Printer.
- When you an output goes through Logical Printer 0 (PR0), the physical output is always directed to the System Target Printer.

By default, the System Target Printer is the Local Printer, that is the printer to which the *Intermate LAN FS3* is installed.

If you have a license key and have enabled the Network Destination Option (NDO), you can—but do not have to—choose another printer instead (Netw1, Netw2, Netw3, or Netw4) as System Target.

If you choose a Netw# printer from the list without having a license key including rights to NDO, the print server will use Local as System Target Printer and write information about the mismatch to the *System Log* (“[Status > System Log](#)” [\(page 110\)](#)).

If you need help in understanding the concepts of Target Printers (physical printers) and Logical Printers, please consult the chapter on [“Processing Facilities” \(page 69\)](#).

7.3. Enable Front Panel Messages (on System Target Printer)

This parameter was introduced in K92_1071. It enables and disables the PJI commands used for writing messages in the front panel of the System Target Printer

The messages in question describe what kind of processing is going on, for example "IPDS Printing", "IPP Printing", and so on.

Values	Comments
Yes	Enable front panel messages. If you have chosen this and the System Target Printer does not support PJI, messages will come out in your print job.
No *	Disable front panel messages.

8. [Network]

Each section in this chapter discusses a single parameter on the [Network] configuration page in the “Configurations > Basic” sub-group.

8.1. Media speed and duplex

Do not change this value without consulting with the responsible system administrator.

Values	Comments
Auto *	Strongly recommended!
10Mbit/sec. half duplex	Force 10 Mbit/sec.
100Mbit/sec. half duplex	Force 100 Mbit/sec.

8.2. Enable Local MAC Address

This parameter was introduced starting with K92_1071. It allows you to override the factory default Global IEEE-assigned MAC address delivered with the *Intermate LAN FS3* for administration of devices according to a corporate strategy. Default is No.

Important:

When you enable a Local MAC address, this will be shown in the browser’s title bar and on the IMCU. Please note that the Local MAC address cannot be used when ordering a license keys for options.

The *Main Status Pages* (“Actions > Print Main Status Pages”—or use the TEST Button) and *Code Revisions Page* (“Status > Code Revisions”) will show both addresses.

8.3. Local MAC Address

If you enable the use of a Local MAC Address, choose the address with care. Connecting devices with identical Local MAC addresses to the network may result in faulty network behaviour that can affect other devices in the network.

In addition, setting a Local MAC Address outside the range indicated below can result in difficulties which can only be resolved by restoring the factory defaults.

Values	Comments
[40.00.00.00.00.00 - 7F.FF.FF.FF.FF.FF]	Hex value. Use upper case letters ONLY. Six dot-separated number groups with two digits in each.

9. Configuring Permissions

The “Permissions” sub-group is located at the bottom of the “Configurations” group and contains two configuration pages.

9.1. [Password Change]

Select User Name

This field will always show the user name `admin` (unless you are an OEM-user).

Enter New Password

The default password for the `admin` account is `admin`.

A password contains maximum 13 characters and is case-sensitive. You can use any ASCII characters within the decimal range 32-126 (see the table on [page 169](#)).

Re-enter Password

In order to set a new password, the text string must be confirmed using the re-enter box.

9.2. [License Key]

Many of our units are delivered with pre-configured license keys. If this is the case, the license key number will be written on a label on the back plate of the unit and you need not use this configuration page.

Otherwise, you must purchase and enter an appropriate software *License Key* in order to use Host Print options (HPO) in production mode or NDO option with or without an HPO option.

A key includes one or more options. The following list is an example; please consult your point of purchase for the correct part numbers:

- Network Destination (NDO)
- HPO for 3270/5250 SCS/TNe
- HPO for 3270/5250 SCS/TNe plus NDO
- HPO for AFP/IPDS (including TNe)
- HPO for AFP/IPDS (including TNe) plus NDO

9.2.1. Ordering a key

License Keys are ordered from your point of purchase. If you bought the *Intermate LAN FS3* from LCI Intermate A/S directly, you can order a key by fax or e-mail (sales@intermate.com).

You must provide the below minimum information.

- 1 The Global MAC Address (also known as the IEEE address or the hardware adapter address).
- 2 The options you wish to purchase.
- 3 Contact information including your name and organisation.

You can find the MAC address on the *Main Status Pages* (use the TEST Button or choose “Actions” > [Print Main Status Pages])—as well as on *Code Revision* (displayed on the screen; you can choose it from the “Status” group on the HTTP menu).

The web title bar will always show a MAC Address, for example as follows

Intermate LAN FS3 Print Server (00C01200F256) - Microsoft Internet Explorer

If the *Local Mac Address* option has been enabled (as explained in “[Enable Local MAC Address](#)” (page 63), the browser title bar will show this local address. This can not be used for the key. Use the *Main Status Pages* or *Code Revision* to find the Global MAC Address.

9.2.2. License Key Entry

The license key you order will be generated uniquely for the MAC address for your *Intermate LAN FS3*. The key consists of four digit groups separated by periods.

When it is generated, each group in the key will always have 3 digits. For example: 167.045.093.281

When you enter the key in the data entry field labelled “License Key”, you must not use any leading zeroes. For example: 167.45.93.281.

Note that you will be overwriting the factory default value of 255 . 255 . 255 . 255 .

When the key is saved and activated, the value shown in the data entry field will again be 255 . 255 . 255 . 255 . But you will be able to see what you have activated by looking just above the data entry field where a value for “Current Product Level” will be displayed.

Entering any value other than your key will disable the features activated by any previously entered key. Features including a test mode will revert to test mode the next time the *Intermate LAN FS3* boots up.

Once you have a license key, it is helpful to write it on a label on the back panel of the unit.

CONFIGURING PRINT SERVICES AND HOST-SESSIONS

10. Processing Facilities

10.1. Introduction

In order to configure the *Intermate LAN FS3* optimally, you should familiarize yourself with how it processes print jobs.

This chapter covers the following topics:

- [“TCP/IP Sessions, Services and Host-Sessions” \(page 70\)](#)
- [“Physical Printers = Target Printers” \(page 74\)](#)
- [““Use Logical Printer”” \(page 75\)](#)
- [“Processing Layers” \(page 76\)](#)
- [“Logical Printers” \(page 77\)](#)
- [“Data Manipulation in the Logical Printer Layer” \(page 79\)](#)
- [““Load Balancing Pools” \(NDO only\)” \(page 84\)](#)
- [“Working with NDO Load Balancing Pools and Data Manipulation” \(page 85\)](#)

There are some sections within several topics which you can skip if you don't use NDO and/or if you don't use the data manipulation facilities in the logical printer layer. Each of these sections are marked at the beginning of the section.

10.2. TCP/IP Sessions, Services and Host-Sessions

A single *Intermate LAN FS3* can handle up to 32 simultaneous TCP/IP sessions. The following tables list the services and host-sessions available.

Figure 3. Services

Input Type/ Protocol	Services
IPP	Internet Print Protocol. one service
Raw Socket TCP Port #	# = 1, 2, 3, or 4 (maximum 4 services in all). Configurable: printer port number, for example 9100
LPR queue #	# = 1, 2, 3, 4, 5, 6, 7, or 8 (maximum 8 configurable services in all) Configurable: queue name and queue type. There are 4 additional pre-configured queues.
FTP print	one service
Novell Netware Rprint/Pserver (Bindery & NDS), or through the NDPS Gateway	One service. Configurable: IPX/SPX frame. Operating Mode, Connection Mode, and other "Netware" options. SAP Availability: IPX/SPX-based Novell service is only available on <i>Intermate LAN FS3s</i> sold before 4 January 2002, up to and including code level K92_1491. All information on this service is found in a separate <i>Printing Environment Manual</i> (published December 2001) available on our web-site.

In connection with the Host Print Options (HPOs), the services are called host-sessions, because what our service does is to initiate a session on the IBM host. These are listed below.

Figure 4. HPO: SCS TN5250E Host Sessions

TN5250E for SCS/DCA L2. This HPO emulates IBM 3812-01 printers

Up to 4 different host-sessions.

SCS Features Supported:

- SCS and SCS/DCA L2 data streams
- 3 bin paper input and duplex
- COR/APO
- IBM font selection
- IBM virtual ASCII transparency
- Multiple Code pages and box drawing
- Full OfficeVision 400 support
- Euro-enabled

A large number of network and processing options are configurable. See the *Printing Environment Guide for IBM OS/400 Systems*.

Note: If you have not purchased and enabled a key, SCS print will be in test mode.

Figure 5. HPO: SCS TN3270E Host Session

TN3270E for SCS. This HPO emulates IBM 3287 printers in LU1 mode
One host-session on IBM Mainframe host (typically S/390 or S/370).
SCS Features Supported:
- SCS (LU1) data stream
- GDDM
-COR/APO
- EAB
- APL2
- RPQs for 3287, 3268 and 4214
- Structured fields and query
- Draft, NLQ and LQ modes
- 3 bin paper input
- Euro-enabled.
A large number of network and processing options are configurable. See the <i>Printing Environment Guide for IBM Mainframe Hosts</i> when it comes on our web-site; until then, consult the equivalent sections in the <i>LAN FS3 10/100 Ethernet User's Guide</i> (KL-008-2).
Note: If you have not purchased and enabled a key, SCS print will be in test mode

Figure 6. HPO: IPDS Host Session

IPDS emulation (using the PPD/PPR protocol) - one host-session
<p>A large number of network and processing options are configurable.</p> <p>IBM printers emulated</p> <ul style="list-style-type: none">- 3812-x, - 3816- 3912/16, - 3112/16- 4028 <p>IPDS Features Supported</p> <ul style="list-style-type: none">• All resident fonts functional equivalent to IBM 3816, 4028, 3916 and 3116 standard fonts. Euro enabled.• Duplex printing• DIN-A3 and Ledger (11x17) support• Data Towers:<ul style="list-style-type: none">- Text- IM Image- IO Image- Graphics- Bar Code• Resource Towers:<ul style="list-style-type: none">- Page Segment- Overlay- Loaded Font- IPDS Exception <p>Available for the following platforms:</p> <ul style="list-style-type: none">- IBM Main-frame (IBM MVS with TCP/P and PSF V2.2)- IBM OS/400 Systems with PSF/400- AIX (V3.2.4 or higher with PSF/6000)- OS/2 Systems (OS/2 with PSF/2, IBM Warp Connect) <p>A printing environment manual exists—or is on the way—for each of these platforms.</p> <p>Note: If you have not purchased and enabled a key, print will be in test mode.</p>

10.3. Physical Printers = Target Printers

10.3.1. Local Printer

The printer in which the *Intermate LAN FS3* is inserted is known as the “local” printer.

10.3.2. Network Printers Using “NDO”

If you have a license key for the Network Destination Option (NDO), you can configure and use up to four network destinations.

The printers you choose for this should support the status information nodes defined in the Printer MIB (RFC1759) and some host information nodes of the Host Resources MIB (RFC1518).

Printers without this support can be used, but no useful monitoring information will be provided in the “Target Printer Information” provided by the *Intermate LAN FS3*. (Target Printer Information is described on [page 109](#).)

10.3.3. The “System Target Printer”

The system target printer is the physical printer on which status information and help can be printed from the HTTP-based menu. By default this is the local printer. If you have a license key for the Network Destination Option (NDO), and do your NDO configuration, you can specify a printer at a network destination instead.

The system target printer has another special feature which we will come back to in the discussion of logical printers.

10.4. "Use Logical Printer"

If you do not use NDO, the only use you will have for configurable logical printers (numbers 1-8 on the table below) is to define data manipulation as explained below in "Processing Layers" (page 76) and "The Configurable Logical Printers 1-8" (page 77).

If you do use NDO, logical printers can also play a role in directing a job to the target printer.

The logical printer definition is the medium through which a printer at a network destination (Netw#) can be chosen. The parameter is called "Use Logical Printer" and it must be defined for every service and host session you will be using.

Use Logical Printer	Directs output to:	
PR0*	Logical Printer 0	No manipulating of data. Users of the Network Destination Option (NDO) please note: The target printer will be the printer designated as "System Target Printer" on the [General] configuration page in the "Configurations > Basic" sub-group.
PR1, PR2, PR3, PR4 PR5, PR6, PR7, PR8	Logical Printer 1 Logical Printer 2 Logical Printer 3 Logical Printer 4 Logical Printer 5 Logical Printer 6 Logical Printer 7 Logical Printer 8	Select one of these queues to have data manipulated by a logical printer definition. Users of the Network Destination Option (NDO) please note: The definition of a logical printer includes choice of target printer.

10.5. Processing Layers

Print jobs sent to the printer are processed in several layers by the *Intermate LAN FS3* before the actual printing occurs.

Figure 7. Processing layers. Read from left to right.

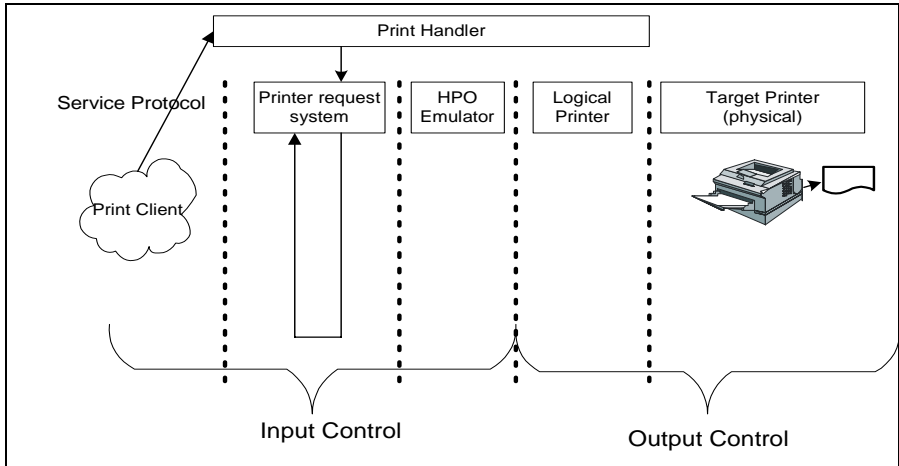

When the job starts, a print handler is started as an instance of the print server, i.e. the *Intermate LAN FS3*. A process is started which “carries” the job through the various layers. The protocol from the print client to the print handler is the one specified in the service.

The print handler asks the printer request system to give the job exclusive rights to use the specified target printer. It makes sure that the job waits until its turn in the print queue and keeps the following jobs at bay until it is their turn.

HPO stands for Host Print Option. The HPO emulator is used when the service is an IPDS, TN5250E, or TN3270E host-session.

When you configure a given service *Intermate LAN FS3*, you must always tell it which logical printer to use. In turn, each logical printer redirects the job to a target printer (or to one pool of target printers (enabled under NDO))

10.6. Logical Printers

10.6.1. PR0

Logical printer zero (PR0) has three special properties:

- It has no data-manipulation capacity. That is, it can not do any pre- or post-job processing and cannot handle substitution strings.
- It is always the default setting for where a given service will send jobs.
- It always prints to the system target printer. It is only by changing the definition of the system target printer ([page 61](#)) that you can change the final destination of jobs that go through PR0.

10.6.2. The Configurable Logical Printers 1-8

You can configure 8 different logical printers, known as PR1 to and including PR8. Following are the parameters you can set for each logical printer you want to use.

Physical printer

Each definition of a logical printer **must** include information on the physical printer it will carry the job to. This will be either a target printer or a pool. Several logical printers can point to the same target printer or to the same pool.

In addition you **can** choose one or more types of **data manipulation** (“pass-processing”) as described below:

Pre- and Post-Job Processing (“String Before and String After”)

Pre- and post-job processing (“string before” and “string after”) enable intelligent selection of advanced finishing options from applications that do not natively support these features.

This kind of processing is especially useful in connection with digital copiers and other types of “Multi-Function Devices” with combined printing and copying facilities.

“String before” could, for example, select a paper cassette,

select an output bin, set the page orientation, and so on. “String after” would typically revoke the effects of “string before”, but can also be used to provoke a page feed at the end of the job, so that there is a separator page, and so on. Each logical printer can have one “string before” and/or one “string after”. Each string can contain many commands.

b) String Substitution

A “substitution string” actually consists of a pair (a set) of strings, one “input” and one “output”. You can define up to 16 substitution strings, assigning any of them to any of the 8 logical printers. This is typically done in order to print characters from another code table, translate characters to escape sequences, call macros and so on.

Each logical printer can use any—all— or none of the substitution strings you have configured.

How Strings Are Written

You must write substitution strings as well as “string before” and “string after” in a printer control language such as HP PCL or Kyocera Prescribe. Detailed information about this is found in [“String Before and String After” \(page 95\)](#), [“\[Substitution Strings\]” \(page 97\)](#), and [“String Syntax” \(page 171\)](#).

10.7. Data Manipulation in the Logical Printer Layer

Note:

Skip [Section 10.7](#) if you will not be working with data manipulation in the logical printer layer.

10.7.1. Examples of Logical Printer Definitions

If you work in a complex environment where you really want to get the most of each multi-protocol print server, it would be a good idea to make a table showing the kinds of capabilities you want to use in each logical printer.

[Figure 8](#) is an example of how to do this. It shows a set of definitions for logical printers, using every day descriptions instead of a printer control language. Even if you only need a few logical printers, it can be inspiring to consider the examples of how the different processing capabilities can be combined. There are two assumptions made in this example:

- a Sixteen sets of input and output strings have been (or will be) defined on the [Substitution Strings] page (refer to the chapter on “[Substitution Strings]” ([page 97](#)) when you need to do an actual configuration). Each “substitution string” has a number. To tell a logical printer that it should use a substitution string, you just list the number in the logical printer definition, just as it is shown on the table below.
- b The Network Destination Option (NDO) is not enabled, so the only target printer available is “local”. Later in this chapter we will see what happens when network printers are added.

Figure 8. Mixed, complex environment but only one printer

Logical Printer	Pre-Processing (String Before)	Post-Processing (String After)	Substitution Strings
0 (zero)	not possible	not possible	not possible
1	input tray 5, output bin 4, sort and staple	restore these settings to what they were before	none
2	input tray 5, output bin 4, sort and staple	restore these settings to what they were before	1, 5, 10, 14
3	input tray 5, output bin 4, sort and staple	restore these settings to what they were before	3, 5, 8, 9, 14, 15, 16
4	input tray 5, output bin3, do not sort	form feed, print a message on the separator sheet then restore these settings to printer's default	1, 5, 10, 14
5	use any input tray available that can print in a landscape orientation, output bin 3, sort	restore these settings to what they were before	none
6	change language code table	restore the previous language code table	2, 4, 5, 11, 12, 13, 14, 16
7	wait for manual feed	none	1, 2, 4, 5, 6, 7
8	none	form feed, print a message on the separator sheet	none

10.7.2. Processing Flows—Examples

By knowing the order in which processing occurs, you can prevent and troubleshoot problems which might arise from combining different kinds of processing.

PR0 always uses a “one-step” process. This is illustrated in [Figure 9](#) and in [Figure 10](#), where the service protocol requires an HPO emulation (in this case SCS TN3270E). Note that the IPDS HPO is placed in the printer, and not in the HPO Emulator layer.

Figure 9. “PR0” (Logical Printer 0)

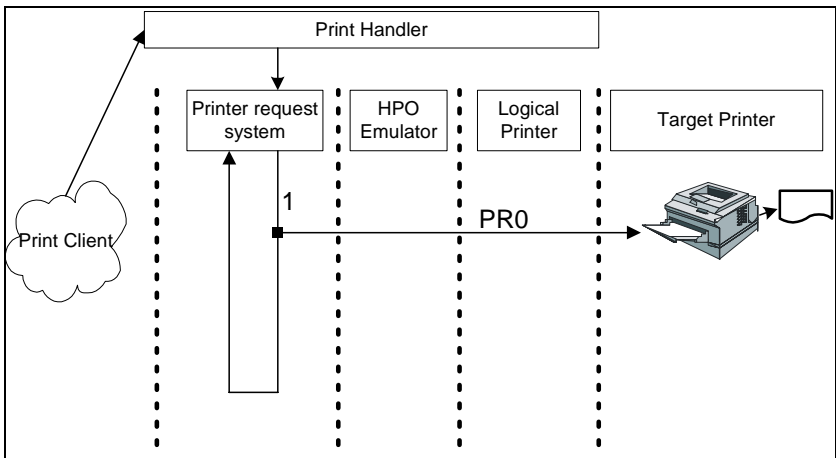
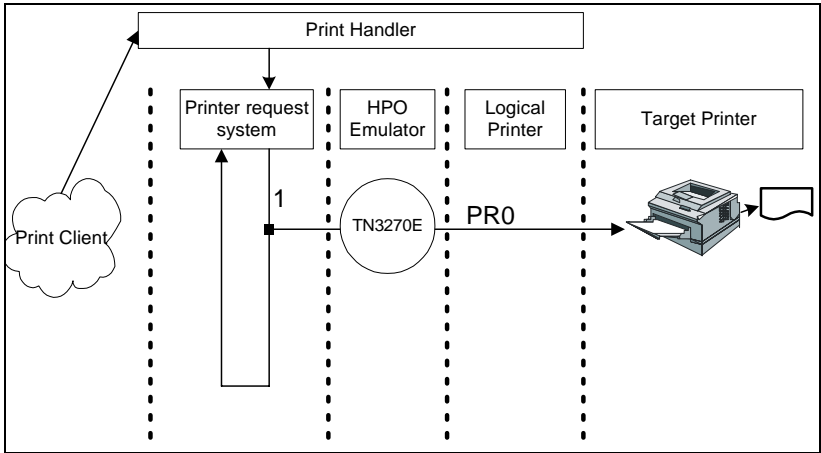
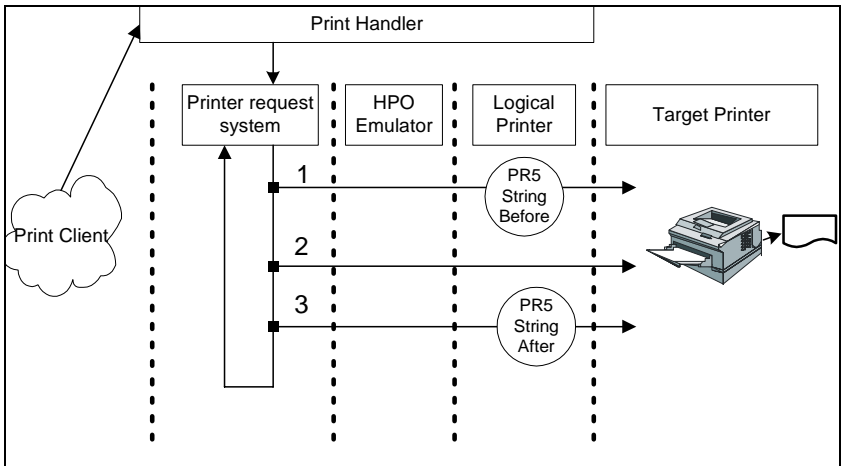

Figure 10. SCS TN3270 through “PR0” (Logical Printer 0)

As soon as a logical printer other than PR0 is involved, the requester must now keep track of three steps, even though it might not use all three of them.

Figure 11 shows a job sent off with a service configured to use a logical printer which uses pre-and post-processing, but no substitution strings. For this example, we assume that the logical printer involved is PR5 (as shown in the examples listed in Figure 8).

Figure 11. “PR5” configured for string before and string after

Finally, let us imagine an example using an HPO emulation (in this case SCS TN5250E) and PR2 as exemplified in [Figure 8](#). The example below in [Figure 12](#) is a bit unusual, because our TN5250 E gives so many configuration possibilities within the data stream. The point is, however, that the *Intermate LAN FS3* can handle any combination.

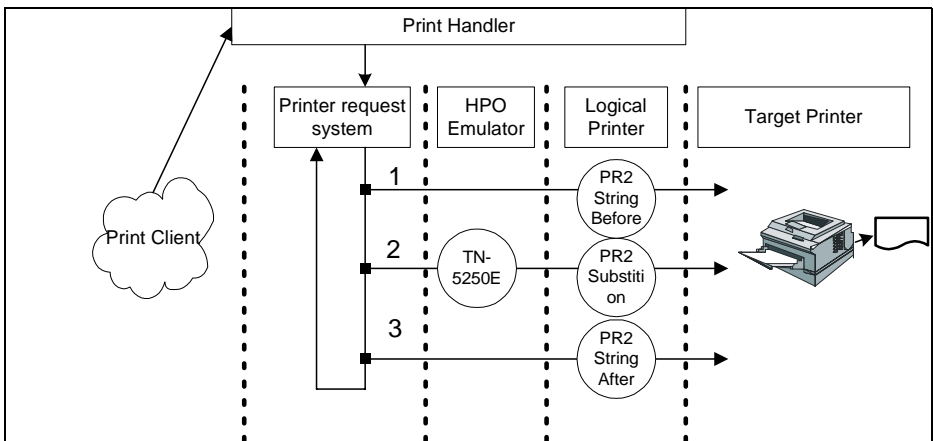
Figure 12. 5250E through “PR2”.

10.8. "Load Balancing Pools" (NDO only)

When you implement NDO, you have the possibility of placing several of the physical, target printers into a common load balancing pool. Load balancing intelligently routes incoming jobs to the first free or least loaded printer in a pool.

Important:

Printers in a pool must have identical processing features, and the safest bet is to only pool identical printers.

Let us assume that the physical printers "local" (0), Netw1 (1), and Netw2 (2) are identical (printer type A) and that Netw3 (3) and Netw4 (4) are identical (printer type B). This means that you can potentially define the following load balancing pools, and note that (for example), 3,4 is not the same definition as 4,3:

0, 1, 2
1, 2, 0
0, 2, 1
1, 0, 2
2, 1, 0
2, 0, 1
0, 1
1, 0
0, 2
2, 0
1, 2
2, 1
3, 4
4, 3

You must use logical printers to define a pool. The practical details of this are explained in "[Load Balancing Pool](#)" (page 93), where principles for ordering your printer number entries are also explained.

If you do not use logical printers for data manipulation, you are finished with this chapter. If you do use logical printers for data manipulation you might want to continue with the next section in this chapter.

10.9. Working with NDO Load Balancing Pools and Data Manipulation

Note: Skip [Section 10.9](#) if you do not use data manipulation in logical printers.

You need to remember the other functions you want performed by that logical printer when you define a pool as the target for a logical printer. So let us return to the practice of making tables to get an overview of configurations. By adding a column to the example in [Figure 8](#), [Figure 13](#) below shows an example of how each logical printers can be set up utilize pooling.

Figure 13. Complex example: logical printer configurations

Logical Printer	Load Balancing Pool	Pre-Processing	Post-Processing	Substitution Strings
0 (zero)	4, 3	not possible	not possible	not possible
1	4, 3	input tray 5, output bin 4, sort and staple	restore these settings to what they were before	none
2	[not a pool: Target = PR0]	input tray 5, output bin 4, sort and staple	restore these settings to what they were before	1, 5, 10, 14
3	1, 0, 2	input tray 5, output bin 4, sort and staple	restore these settings to what they were before	3, 5, 8, 9, 14, 15, 16
4	2, 0	input tray 5, output bin3, do not sort	form feed, print a message on the separator sheet then restore these settings to printer's default	1, 5, 10, 14
5	[not a pool: Target = PR4]	use any input tray available that can print in a landscape orientation, output bin 3, sort	restore these settings to what they were before	none
6	1, 0, 2	change language code table	restore the previous language code table	2, 4, 5, 11, 12, 13, 14, 16
7	[not a pool: Target = PR3]	wait for manual feed	none	1, 2, 3, 4, 5, 6, 7
8	2, 0, 1	none	form feed, print a message on the separator sheet	none

This is a pretty complex example to illustrate what is possible. Don't try to fully understand the details shown. When you start configuring your own systems, the details will make sense to you.

To be complete in your planning, you must consider which types of input will be sent to which logical printer. The final example below shows this; at the same time, it reflects a more realistic situation entailing less complicated use of pre-processing, post-processing and string substitution than in the previous figures.

Figure 14. Simpler example: services and logical printers

Types of input configured to...	Logical Printer	Load Balancing Pool]	Pre-Processing (String Before)	Post-Processing (String After)	Substitution Strings
FTP, Raw-4, LPR-5	0 (zero)	0, 1	not possible	not possible	not possible
SCS 5250E	1	3, 4	none	none	none
SCS 5250E	2	0, 1, 2	none	none	none
SCS 5250E, LPR-7	3	3, 4	none	form feed, print a message on the separator sheet	none
SCS 5250E, LPR-8	4	0, 1, 2	none	form feed, print a message on the separator sheet	none
IPP, ThinPrint, Raw-2, LPR-2, LPR-6	5	4, 3	none	form feed, print a message on the separator sheet	1, 5, 10, 14
LPR-3, Raw-3	6	0, 1	change language code table	restore the previous language code table	2, 4, 5, 11, 12, 13, 14, 16
LPR-4	7	3, 4	wait for manual feed	none	1, 2, 3, 4, 5, 6, 7
LPR-1, Raw-1	8	0, 1, 2,	none	form feed, print a message on the separator sheet	none

11. Network Destination Option

The menu item is called "Network Printers (NDO)" and configuration page is called [Network Printers (NDO)].

11.1. Requirements

You can configure and save the configurations for up to four "Network Target Printers", also known as "Network Destinations". You will not be prevented from saving NDO configurations if you have no NDO key. However, all printed output will be routed to the local printer. In addition, an error will be written to the *System Log* (see ["Status > System Log"](#) (page 110)).

11.1.1. Recommended Features for Network Target Printers

The *Intermate LAN FS3* retrieves printer status information from the Network Target Printer through SNMP. For this to function properly, a network printer must support the status information nodes defined in the Printer MIB (RFC1759) and some host information nodes of the Host Resources MIB (RFC1518).

If the target printer lacks these features, printer halts (Paper jam, Paper out, Off-line etc.) at a Network Target Printer will be interpreted by the *Intermate LAN FS3* as "busy" until a user has fixed the problem.

11.1.2. Configurations for Each "Network Printer #"

The path to the configuration page covering all 4 printers is: "Configurations > Output Control > Network Printers (NDO)" Each set of parameters is labelled Network Printer # and lines are used to separate the sets from each other. Parameters:

- ["Hostname"](#)
- ["Print Method"](#)
- ["Raw Socket TCP Port"](#)
- or ["Printer LPR Queue Name"](#) and ["LPR Count Byte \(MB\)"](#).

11.2. Hostname

This parameter specifies the address of the of a network target printer (or rather, the address of its LAN connection).

Values	Comments
IP address or	4 dot-separated bytes, each within the range [0..255]
DNS registered name	Maximum 47 ASCII characters. It is best to observe the restrictions described for host names on page 58 . The name must be registered on the DNS server specified in [TCP/IP Settings] > "DNS Server IP Address" (page 59)

Default is blank. If the field is left blank, the particular network destination is regarded as disabled.

11.3. Print Method

"Netw# Print Method" concerns output, and brings the job from the logical printer to a network target printer.

The choice of Raw Socket or LPR for this print method is independent of the print protocol for a service ("Input Control" subgroup), where the protocol brings the job as far as the logical printer.

Values	Comments
Raw Socket *	Establish a Raw Socket (port 9100; Reverse Telnet) with the network printer you are configuring. If Raw Socket is chosen, you must also fill out Raw Socket TCP port number.
LPR	Print to an LPD Daemon. This is a more complex protocol which should only be used if network printer you are configuring can not handle Raw Socket. If LPR is chosen, you must also fill out LPR Queue Name and LPR Count Byte.

11.4. Raw Socket TCP Port

This parameter specifies the Raw Socket TCP port number used on the target printer at destination #. It will be ignored if you choose LPR as “Netw# Print Method”.

Value	Comments
9100* [1024..65500]	Refer to the manual for the printer to determine available Raw Socket port numbers.

11.5. Printer LPR Queue Name

This parameter contains the name of the LPR queue name used on the target printer at destination #. It will be ignored if you choose Raw Socket as “Netw# Print Method.”

Values	Comments
<qname>	Maximum 8 ASCII characters. It is best to observe the restrictions described for host names on page 58 .

Use a logic for naming queues that fits well into your environment. The configuration page shows a default name LPQ1 in each of the four possible slots, and you need not change these names, given that each network destination has a different host name.

11.6. LPR Count Byte (MB)

LPR is a spooling protocol, which normally requires a count byte to indicate the size of the job to the LPD daemon.

Because the *Intermate LAN FS3* does not have the ability to spool the job in order to verify the total length, it is necessary to specify a “Receive Data File” byte count in MBytes for the LPR job. Valid values are in the interval [0..2147], and 2147 is default.

In order to choose the correct value for the network destination in question, you need to investigate how the LPD Daemon is integrated on the printer which will be targeted at that destination.

According to the LPR/LPD RFC1179 a byte count of zero will indicate an infinite size. This is for example accepted for the LPD integration in Windows NT.

LPD Daemons not accepting a count byte of zero may accept a byte count larger than the job (i.e. a client disconnect before the byte count is reached). Defining a byte count value larger than the largest expected LPR print job may therefore have the same effect as a byte count of zero.

12. [Logical Printers 1-8]

12.1. Introduction

All eight configurable logical printers are set up on a single configuration page in the HTTP interface. Each set of parameters is labelled "Logical Printer #" and lines are used to separate the sets from each other.

For each configurable logical printer PR1 - PR8 there are five fields: one mandatory, one conditionally mandatory, and three optional fields.

Target Printer (1-2 mandatory fields)

You must choose a target printer from the drop-down list for that field.

If you use the NDO and choose "pool" instead of a single target, you must also define the pool in the field following. Printers in a pool should all function identically (as described in ["Load Balancing Pools" \(NDO only\)"](#) (page 84)).

Up to 3 optional fields for data manipulation

- String Before
- String After
- String Substitutions

Order of fields within each set

On the configuration page, the optional fields appear first in the set of parameters defining a logical printer, while the target printer definition comes last.

12.2. Target Printer

This parameter specifies the destination of the printed output to be used in connection with the logical printer you are configuring.

If you are not using NDO, the only possibility is to keep the default which is Local (0).

If you are using NDO, you can choose among six possibilities for a given logical printer:

- Local(0)
- Netw1(1)
- Netw2(2)
- Netw3(3)
- Netw4(4)
- Pool

"Local" is also referred to as the local port and refers to the KUIO port of the Kyocera printer in which the LAN FS3 is installed.

If you choose a Network Destination which has not been defined in ["Network Destination Option" \(page 87\)](#), and then send a job to the logical printer in question, the job will be discarded and an error message will appear in the *System Log* (see ["Status > System Log" \(page 110\)](#)). The same thing will happen if you have defined a Network Destination, but have no NDO license key installed.

If you choose "pool", you must also fill in the next field in the block defining the logical printer you are configuring.

12.3. Load Balancing Pool

This parameter is only used when the target printer for a logical printer definition is set to “pool”. It specifies the already defined network target printers which are to be included in the load balancing pool.

If you choose “pool” as the target printer, but leave the “load balancing pool” field blank, print jobs sent to the logical printer in question will be discarded and a message will be generated in the System Log.

The values to enter from the set [0, 1, 2, 3, 4] refer to the values in round brackets on the pull-down menu for “[Target Printer](#)” (page 92). You can enter any combination, assuming that the combination you choose only includes printers with fully equivalent functionality.

Listed network destinations not having a valid IP host address configured will be excluded from the pool.

If none of the network destinations listed in the pool have been configured with a valid IP address, the local port (0) will be used.

Determining the order of values to enter

The order in which the target printer numbers are listed determines priorities. In other words, the order of the list determines the order in which the *Intermate LAN FS3* tests to see where a job should be sent.

Prioritizing is only activated in situations where two or more target printers in the load balancing pool are idle.

If all output ports in the load balancing pool are busy, a new incoming job will be destined to the queue in the pool that first becomes idle regardless of the priority.'

It is often a good idea to put the least heavily used printers at the start of the list.

Example	Comments
4,0,3,2	Network Destination 4 has the highest priority, followed by the Local Port and Network Destination 3. Network Destination 1 is not included in the pool.

See [““Load Balancing Pools” \(NDO only\)” \(page 84\)](#) and [“Working with NDO Load Balancing Pools and Data Manipulation” \(page 85\)](#) for examples of what you need to think about when you plan pools.

12.4. String Before and String After

The data manipulation provided in "string before" and "string after" for a given logical printer make it possible to send **printer control commands** before and after the actual data stream in the print job. Examples of how these manipulations are used are found in the chapter on ["Processing Facilities"](#) (page 69).

Each logical printer can have one "string before" and one "string after". The maximum number of "Encoded Bytes" you can use in "String Before" and "String After" depends on the identification number of the logical printer involved as shown below. See the appendix on ["String Syntax"](#) (page 171) for an explanation of "Encoded Bytes".

Figure 15. Maximum number of Encoded Bytes

Maximum number of encoded Bytes in PR# String...		
Logical Printer	... Before	... After
1	500	100
2	500	50
3	500	50
4	500	50
5	200	50
6	200	50
7	200	50
8	200	50

In K92_1071 the number of characters in "String After" was reduced from 100 to 50 for logical printers 2-8 in order to increase the number of characters available for "String Before". "String After" definitions made under previous releases using more than 50 characters will be truncated to 50 characters when upgrading. .

12.5. String Substitutions

As mentioned in *“The Configurable Logical Printers 1-8”* page 77, it is possible to set up a logical printer to do string substitution. The strings are defined in the next configuration page in the "Output Control" sub-group (*“[Substitution Strings]”* (page 97)).

If you want the logical printer you are configuring to use one or more of these strings, enter all the relevant string numbers in the "String Substitutions" field for the logical printer you are configuring. The numbers you enter must be separated by commas.

This is trivial. What is challenging is planning the content of your substitution strings and entering them in a meaningful order. This is covered in the section on *“Planning”* (page 98) in the *“[Substitution Strings]”* chapter.

13. [Substitution Strings]

13.1. “Input String #” and “Output String#”

The [Substitution Strings] configuration page consists of 32 fields.

They are paired as follows:

Input String 1
Output String 1

...
...

Input String 16
Output String 16

So you can define up to 16 substitutions; think of them as 16 string sets (pairs).

The syntactical rules for input strings and output strings are the same as for “String Before” and “String After” (as described in “[Logical Printers 1-8]” (page 91)).

Each input string or output string can fill up to 100 encoded Bytes (see “Basic Rules and Encoded Bytes” (page 171) in the appendix on string syntax).

String sets entered in the [Substitution Strings] configuration page have no effect until you set up a logical print which will use one or more of them (“String Before and String After” (page 95)).

When your chosen logical printer is configured to use a given string set, the data stream in a job directed to that logical printer will be inspected. If there is a string exactly matching “Input String #”, it will be removed and be replaced with “Output String #” in the same set.

13.2. Planning

As shown in “[[Logical Printers 1-8](#)]” ([page 91](#)), it is easy to tell a logical printer to use one or more (even all) of the string pairs defined in [Substitution Strings].

What is difficult is the planning when you want more than one substitution string to be used. If there is any overlap in the content of the input strings, you must carefully control the order in which you enter the string # in the “String Substitutions” field for the logical printer in question.

Example: You want to use the following substitution strings in logical printer x, where the input strings encode like this:

Input String 1: trs98

Input String 5: trs98563

Input String 8: 98

Input String 8 is a subset of Input String 1, which in turn is a subset of Input String 5.

If you want to be sure that everything is interpreted correctly, you must order your entries in the “String Substitutions” field like this:

8 , 1 , 5

So, if you will be using substitution strings, you should define what they are to accomplish and number each pair of input and output strings, and examine them in detail. Do this on paper before you start entering data in the *Intermate LAN FS3*.

For inspiration, see the examples in “[[Data Manipulation in the Logical Printer Layer](#)]” ([page 79](#)) and “[[Working with NDO Load Balancing Pools and Data Manipulation](#)]” ([page 85](#))

14. Services in “Input Control”

This chapter covers configurations for Raw Socket, LPR, FTP Print, and IPP.

14.1. Raw Socket

You can configure up to four Raw Socket services.

All four are configured on the same configuration page.

Each configuration requires you to set two parameters, where # is the number of a given Raw Socket service.

1 Which TCP Port to use.

Type in a value for “TCP Port #”. Default is 9100.

Raw Socket is traditionally assigned to printer port 9100, and is sometimes even called the “port 9100 protocol” (or the Reverse Telnet Protocol). You can, however, choose any value within the range [1024.. 65500], given that the value chosen is consistent with a printer definition used to print Raw Socket via the *Intermate LAN FS3*.

2 Where to direct the output:

Choose a value for “Use Logical Printer #”. Default is PR0. The other possibilities are PR1 - PR8, inclusive.

If you need help to understand how output is directed, please consult the chapter on “[Processing Facilities](#)”, especially the sections “[“Use Logical Printer”](#)” (page 75) and “[The Configurable Logical Printers 1-8](#)” (page 77).

If you will only be using one Raw Socket service, leave all the fields in their default.

If you want to use more than one Raw Socket service, you need to plan how you will differentiate them from each other.

The (host) environment from which you send jobs can only find its way to processing in the *Intermate LAN FS3* via the port

number which is part of any given printer definition.

This means that if you want to use the special processing facilities in a logical printer, you must use a different port number to point to each of the logical printers you want to use.

For example

TCP Port #	Port Designation	Logical Printer
1	9100	PR0
2	9101	PR4
3	9102	PR5
4	9103	PR8

Remember to "Save & Cont." and then "Reboot" to activate.

14.2. LPR Print Queues (LPD Protocol)

The *Intermate LAN FS3* supports up to 12 LPR queues. Eight of them are configurable while four are pre-configured. Each queue is identified by the following three parameters:

- a name
- b queue type
- c where to direct the output (as described under [Point 2 on p.99](#)).

The name must, of course, be known to the (host) environment(s) from which you will send jobs.

On the configuration page, the "name" fields for the configurable queues have been filled out with defaults LPQ1, ..., LPQ8. If you want to change the queue name, note that it must consist of maximum 8 ASCII characters. Check the documentation for your host systems for syntactical restrictions, or observe the restrictions described on [page 58](#).

Each queue type either sends the data stream through without any conversion ("binary"), or converts the data stream to ASCII. In addition, the queue type determines whether or not a form feed will be used after the data stream is finished. So, there are four types in all, as shown in the table below:

Type
Binary transfer, no conversion.
Binary plus form feed after * This is the default type if no queue name match is found
ASCII transfer (LF => LF-CR conversion).
ASCII plus form feed after

Remember to "Save & Cont." and then "Reboot" to activate.

The four pre-configured LPR queues look like this (see the table on the next page):

The four pre-configured LPR queues:		
Queue Name	Type	Output is directed to
PAR_B	binary	PR0
PAR_BF	binary plus form feed	PR0
PAR_A	ASCII	PR0
PAR_AF	ASCII plus form feed	PR0

You will probably not need to define any other queues to point to PR0, but may well want to configure one or more queues to point to other logical printers.

14.3. FTP Print

All you need to do is choose where you want the output of FTP jobs directed (as described under [Point 2 on p.99](#))— and, of course, check to be sure that the logical printer points to the desired physical printer.

Before code level K92_1071, it was only possible to direct output to PR0.

Remember to "Save & Cont." and then "Reboot" to activate.

14.4. IPP Print (Internet Printing Protocol)

IPP print, version 1.0 and 1.1, is supported with all mandatory features and services plus some optional ones.

IPP support allows the user to print across the internet and intranet to a printer with an accessible IP address.

IPP retrieves information on this printer's capabilities and features such as color, duplex, paper sizes, etc. The user has full control over print jobs (print objects) and can even cancel print jobs after they have been submitted.

All you need to do is choose where you want the output of IPP jobs directed (as described under [Point 2 on p.99](#))— and, of course, check to be sure that the logical printer points to the desired physical printer.

Remember to "Save & Cont." and then "Reboot" to activate.

Client-side configuration

The IPP server can be reached on port 631 and the print service is called "printer". See the *Printing Environment Guide for Windows* for a sample configuration (after 28 February 2002).

MANAGEMENT— INFORMATION AND MONITORING POSSIBILITIES

15. Printed Information Available

15.1. Main Status Pages

The Main Status Pages make it possible for you to see all of the settings you have configured and can be invaluable as a reference. The structure of the information follows that of the menu you will see if you use a browser for configuration.

Besides listing the current configurations, the *Main Status Pages* also include information on firmware levels and everything that has been written to the *System Log* since the last reboot.

Initiate the print remotely by using “Actions” > [Print Main Status Pages] on the HTTP menu; the HTTP menu is the only configuration and management tool that can do this. Alternatively, you can use the TEST Button to get your print. See [“TEST Button to Print Main Status Pages or Quick Guide” \(page 168\)](#) in the appendices.

Regardless of your choice—HTTP menu or TEST Button—the printout is always directed to the printer you have set to be System Target Printer ([page 61](#)).

If the System Target Printer is the local printer, pressing the printer’s own “status” button or choosing to print the status from an operator panel will sometimes print the print server’s *Main Status Pages* after the printer’s own status pages are finished printing; this depends on the printer model

15.2. Other Printouts in the "Actions" Group

Users of TN5250E are provided with three extra kinds of printed configuration information.

- SCS5250 IDB Status
- SCS5250 IDB Dump
- SCS5250 Font Dump

15.3. "Help" > [Quick Guide]

This is the same mini-manual that you can get printed out by using the TEST Button (as explained in the *Getting Started* brochure and in this guide, "[TEST Button to Print Main Status Pages or Quick Guide](#)" (page 168)). The txt-file is also available on our web-site and on the CD-ROM.

16. Standard Monitoring Information

16.1. The “Status” Group on the HTTP Menu

Items on the “Status” group always result in information displayed to the screen. If you want to print it out, activate the main window by clicking somewhere on it and then use your browser’s “print” button.

If you have the optional “serial software downloading cable RJ45 - DB9” and a tool such as *HyperTerminal*, you can watch error messages, warnings and many other kinds of messages (for example in connection with upgrades) in real time. The *Intermate LAN FS3* has its own serial I/O (console) port.

The following items are always available in the “Status” group:

- “Target Printer Info” (see [page 109](#))—only applicable to printers at network destinations.
- “System Log” (see [page 110](#)). This contains mostly warnings and error messages, and these are described on [page 111](#).
- “Code Revisions”. This will give you very detailed information which you will rarely need unless (for example) you are doing some troubleshooting with a supporter.
- “Printer”—that is the printer in which the *Intermate LAN FS3* is inserted, the local printer. This status information is limited to telling you if the printer is “Ready” or in a particular error condition, such as paper jam, out of paper, etc.

The following items are only available in the “Status” group if relevant settings have been enabled at various places in the system:

- WINS
- IPX/SPX (discontinued in *Intermate LAN FS3* after code level K92_1491)

- TN5250E
- TN3270E

16.2. "Status > Target Printer Info"

Here is an example of Target Printer Info where one network printer has been defined and activated

Target Name: Netw1

Target Communication Protocol: Network - RAW Socket

Printer Name: FS-3700+

Bidirectional Support: Yes

Printer Status: READY

Display Message: [Unavailable]

Online Status: Online

Job Boundary Page Counter: 0

Total Page Counter: 57239

Duplex Print: Off

Job Queue: No Job in Queue

Note: The information on status for a network printer / network destination is only available and reliable if the printer at this network destination supports SNMP-based queries (see ["Recommended Features for Network Target Printers"](#) (page 87),

16.3. "Status > System Log"

The *System Log* lives from reboot to reboot.

When you choose "Status >System Log", the current information is displayed on screen, labelled Status [System Log].

Note that the current information in the *System Log* is also included in the print of the *Main Status Pages* (see [page 106](#)).

16.4. Warnings and Error Messages

Here are the kinds of warnings and error messages that can appear, mostly in the System Log, but sometimes flashed real-time and directly on the screen.

16.4.1. Messages requiring you to seek help from a point of purchase

- “Unsafe adapter address detected (MAC). Probably not set yet” This indicates a serious problem. Contact your point of purchase.
- License key messages:
 - “No license key found for ThinPrint”
 - “At least one logical printer is set up to use NDO. Sorry, no license key found. Using LOCAL.”
 - “System target set up to use NDO. Sorry, no license key found. Using LOCAL.”

16.4.2. Messages about things you can fix yourself

- “Load Balancing Pool used. Found no valid targets in pool.”
- Target printer not ready yet, or invalid configured”
- “Failed to connect to target printer”
- “LPR target refused job”
- “Used a logical printer with no valid target configuration”
- When you are working with a configuration page and type an invalid value in an input field, the configuration page will be replaced with a page telling with the following message:
“Error in input field '<parameter name>. Press the Browser’s Back Button”
- You may also see information on forced value changes, which may or may not require action on your part.

17. Configurable Monitoring Tools

17.1. [IMCU Agent]

If you already have given an *Intermate LAN FS3* an IP address, you can activate the embedded agent on it.

Log in to the *Intermate LAN FS3*.

Browser users: choose the [IMCU Agent] configuration page in the "Status Monitoring" sub-group.

Telnet users: choose the *IMCU* menu item.

Enable the function and enter the port number. Default is 8888. Do not change this without a very good reason.

For more information on the *IMCU*, see ["The Intermate Management and Configuration Utility \(IMCU\)"](#) (page 35).

17.2. [E-Mail Notification]

Choose [E-Mail Notification] in the “Status Monitoring” sub-group.

Parameter	Default Setting	Comments
Enable E-Mail Notification	No	Enable the function using the radio button.
SMTP Server Address	>Blank<	Enter the IP address of the mail server. Alternatively you can enter a name if this name is on the DNS server registered on the [TCP/IP] configuration page in the “Basic” sub-group.
Mail Receiver Address	>Blank<	This can be anyone who might be expected to respond to the message.
Administrator E-mail Address	>Blank<	This address will be presented on a mail as the sender.
On what occasions should an autogenerated notification message be sent?:		
Notify on 'Off-line'	Yes	When you enable E-Mail Notification, all of the “Notify on...” parameters will be enabled by default. You can disable them by changing the radio button choice from “Yes” to “No
Notify on 'Out of Paper'	Yes	
Notify on 'Paper Jam'	Yes	
Notify on 'Cover Open'	Yes	
Notify on 'Toner Low'	Yes	
Notify on 'Printer Error'	Yes	
Notify on 'Power Off'	Yes	

Some of the **identifying information on the mail** comes from mandatory settings, such as IP address and host name, or from system information, such as code level. The rest comes from what is entered on the [General] Configuration page. The sender is identified with the following syntax:

```
<Device Name> <Print Server Hostname>
<<administrator's mail address>>
```

Example:

```
Accounting fs3-a
<jjj@mycompany.com>
```

The mail will also show “System Admin. Contact” and “Device Location”.

18. Configure [SNMP]

18.1. Introduction and Pre-Requisites

The *Intermate LAN FS3* can be configured so that you can use SNMP-based network tools to manage many printers and monitor their activity in detail.

Several software programs exist that provide an easy to use interface for network management via SNMP. One of the most popular is the node management program *HP OpenView* which is used in this manual (version D.03.02 for Windows).

The operations and settings referred to should be easily recognizable in case another program is used. However, it is always a good idea to refer to the documentation supplied with your SNMP software for help and details.

Code level

Configuration and management via SNMP requires Main Code K92_1071 or higher

MIB

You will need a *Private MIB* (Message Information Base) file. This is available from Kyocera-Mita. Store the file in a logical location, for example in a directory named after your printer or on a floppy disk.

18.2. Set Up a Connection With Your SNMP Tool

To set up a connection

- 1 Start *HP OpenView*.
- 2 Create an icon for the printer to be configured. Open the Add menu by choosing “Edit > Add..” in the menus.



Set the type of connection to “Computer” and choose the “Printer Server” icon for representation.

Drop the icon in the submap window by left-clicking on it and dragging it.

When the icon is placed you are asked to describe the “Printer Server.”

- 3 Type in a suitable printer “Name”, the “Network Address” (IP address) and MAC Address of the *Intermate LAN FS3*.

The MAC address must be entered without spaces or points. You can find the IP- and MAC-addresses on the *(Main) Status Pages* which you can print either from the TEST Button (see [“TEST Button to Print Main Status Pages or Quick Guide”](#) (page 168)) or from the HTTP menu (“Action” > [Print Main Status Pages]).

When you are done, click the “OK” button and close the “Add” menu.

- 4 Check the new connection by pinging the *Intermate LAN FS3*.
Do this by right-clicking the icon in the “Submap” window and choosing “Ping” This opens the “Ping” window. Press the “Start” button and wait for a reply. If the connection is

okay, a message starting with the words “Reply from...” appears. If no message appears check the connection, *Intermate LAN FS3* and printer.

- 5** Once the connection has been set up you must save it. Do this by choosing “File > Save As...”.

18.3. Edit “Variables”

With *HP OpenView* queries are used to show the contents of variables (corresponding to our parameters).

To define a query and edit variables

- 1 Start *HP OpenView* and choose the connection you wish to work with.
- 2 On the main screen choose “Control > SNMP Manager... > Define Query...”.

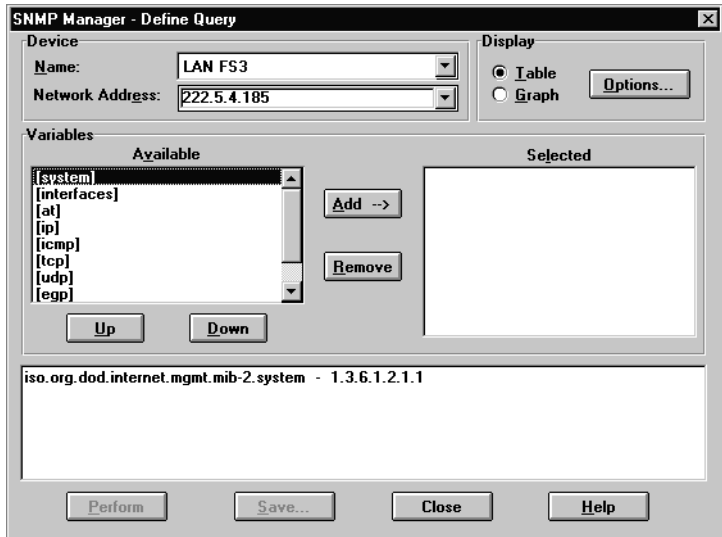

- 3 Choose the variables you wish to view from the “Available” list and add them with the “Add -->” button to the “Selected” list.
Press the “Perform” button when done. This opens a window showing the contents of the chosen variables.
- 4 Edit the variables. Leave the dialogue box by clicking “Close”.

18.4. Load and Edit “Options” (Parameters)

Intermate LAN FS3 parameters can be edited with SNMP management program after the *Private MIB* has been added to the MIB database.

To add the Private MIB

- 1 Start *HP OpenView* and choose the connection you wish to work with.
- 2 In the main screen choose the “Control > SNMP Manager. > Manage Database.”. This opens the Manage Database window.
- 3 Choose the file named *rfc1213.mib* in the list of available MIB files and press the “Add->” button.
- 4 Add the *Private MIB* file by pressing the “Import...” button. Locate and choose the file and press the “OK” button.
- 5 Back in the Manage Database window select the *Private MIB* file and click the “Add->” button.

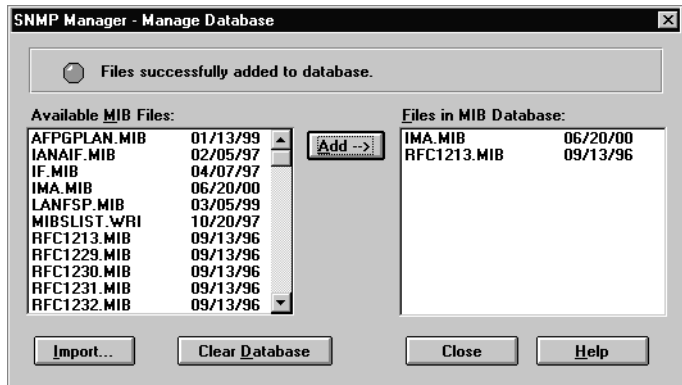

- 6 Click the “Close” button.

To edit the *Intermate LAN FS3* parameters

- 7 On the *HP OpenView* main screen choose "Control > SNMP Manager... > Define Query...". This opens the dialogue box for defining queries. Note that the parameters will be called "variables".
- 8 Select the variables to view and add them to the "Selected" list. The *Intermate LAN FS3*-"option" variables are found by clicking "iso > org > dod > internet > private > enterprises > intermate > imaPs1". This brings up a list of all available "option groups" (each corresponding to a configuration page). Double-clicking an "option group" name accesses the variables contained in that group. Select the variables or groups to be viewed. Use the "Add ->" button to add single variables or entire groups to the list. Finish by pressing the "Perform" button.

Example: The figure below shows the variables found in the "General" option group (= the parameters found on the [General] configuration page in the print server's HTML dialog).

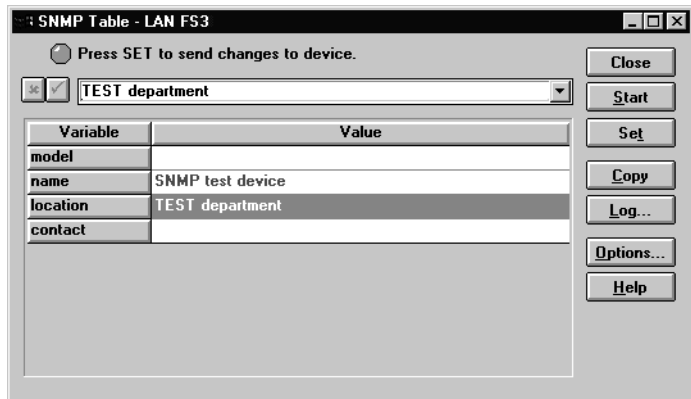

- 9 Edit the variables.
- 10 Click the "Close" button to finish.
- 11 Power the printer Off and On (but wait 10 seconds after saving the "options" before powering Off).

- 12 Ping the *Intermate LAN FS3* to verify that it is ready. This can be done by right-clicking the connection in the submap window and choosing "Ping.". Press the "Start" button to ping a single time. Repeat the pinging until the *Intermate LAN FS3* replies.

Tip:

The pinging can be set to be performed continuously by checking the *Continuous Operation* feature in the Option menu.

18.5. Traps

Traps are used to monitor the printer and to report errors and attempts of unauthorized user access.

The kinds of traps which are generated are controlled on the *Intermate LAN FS3's* [SNMP] configuration page using the parameters [Enable Authentication Traps](#) (Default setting: *No*) and [Enable SNMP Printer Traps](#) (Default setting: *No*).

The receivers of the traps are specified with [Trap Target](#) (Default setting: *>Blank<*). The receiver's community is set with [Trap Community](#) (Default setting: *public*).

The traps that can be generated based on printer events are listed below.

Figure 16. SNMP Printer Trap Numbers

Printer trap no.	Printer event	Parameter	Default Setting
1	Printer ready	-	-
4	Printer off-line	Trap on 'Off-line'	Yes
32	Out of paper	Trap on 'Out of Paper'	Yes
128	Cover open	Trap on 'Cover Open'	Yes
512	Paper jam	Trap on 'Paper Jam'	Yes
1024	Toner low	Trap on 'Toner Low'	Yes
8192	Undefined error	Trap on 'Printer Error'	Yes

In addition to these come traps generated by unauthorized attempts of viewing or editing options.

To set up traps

- 1 Start *HP OpenView* and choose the connection you wish to work with.
- 2 On the main screen, choose "Options > Customize Traps".

- In the box just opened, select the “Device Class Name” called 1.3.6.1.4.1.1527 with the enterprise number 1.3.6.1.4.1.1527.

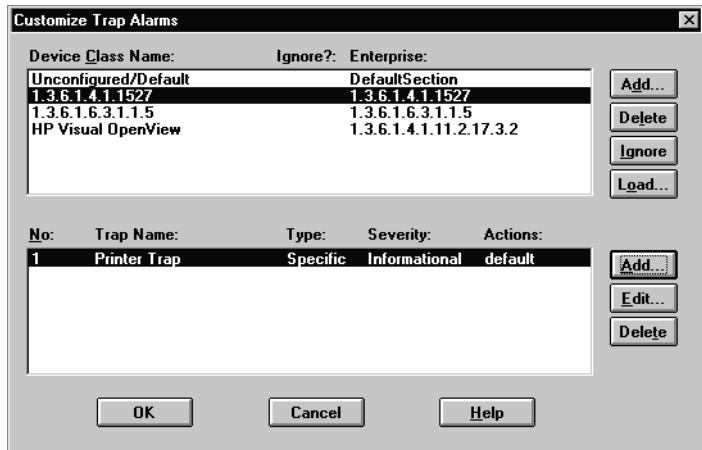

Note:

It is NOT necessary to add any extra device classes in order to receive traps from the *Intermate LAN FS3*.

- Press the “Edit...” button in the lower part of the dialogue box.

- 5 Edit the fields as shown below and click “OK”.

- 6 Close the “Customize Trap Alarms” box.
 7 Log on to the *Intermate LAN FS3*.
 8 Choose “Configurations > Status Monitoring” > [SNMP] to set the parameters you want.

Parameter	Default Setting	Comments
Monitor Community	public	
Control Community	public	
Trap Community	public	Set this to a value other than <i>public</i> to control who should receive traps.
Trap Target	>Blank<	The receivers of traps are specified by their IP addresses. IP addresses must be entered with the ASCII character one as lead-in, e.g. 1192.168.4.185 For Novell Netware under IPX/SPX Use the IPX/SPX address. IPX/SPX addresses be entered with the ASCII character zero as lead-in, e.g. 0000000400c0a2050729

Parameter	Default Setting	Comments
Enable Authentication Traps	No	Set this to Yes to enable traps on attempts of unauthorised access.
Enable SNMP Printer Traps	No	Set this to Yes to enable traps on printer errors.
Trap on 'Off-line'	Yes	-
Trap on 'Out of Paper'	Yes	-
Trap on 'Paper Jam'	Yes	-
Trap on 'Cover Open'	Yes	-
Trap on 'Toner Low'	Yes	-
Trap on 'Printer Error'	Yes	-

9 Reboot the *Intermate LAN FS3*.

18.6. Using and Viewing Traps

Now that everything is set up, whenever a printer error occurs, a trap is sent and the icon for the established connection on the main screen turns red. The traps can be tested by generating some printer events. Try for example to open the cover and then view the trap.

- 1 Right click the connection icon on the main screen and choose “Alarms..”



- 2 Choose a connection in the Alarm Log by clicking on it once.
- 3 Click the “More Info..” button to view more details on the trap received.

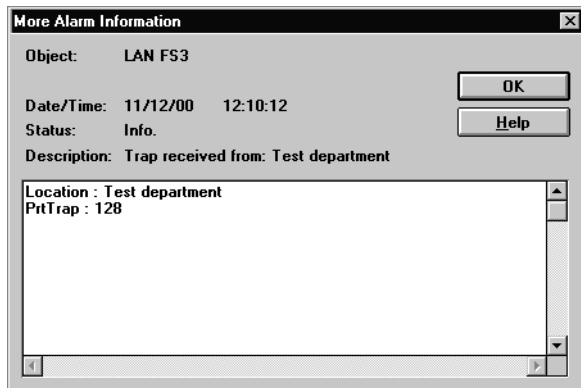

Look up the number in [Figure 16 “SNMP Printer Trap Numbers”](#)

(page 122). The number (128) of the received trap indicates that the cover of the printer is open.

19. The KPM Printer Utility (External Tool)

19.1. Purposes and Limitations

The *Kyocera Print Monitor (KPM)* PC-program uses SNMP to retrieve the printer status and for printer configuration.

The KPM-program is available for download at the Kyocera web site. Look for example at <http://www.service.kyocera.de/>. The program runs on 16 and 32 bit Windows platforms.

KPM is capable of retrieving the status of many printers supporting SNMP including non-Kyocera printers. It is also capable of receiving status messages sent from a printer to the *Intermate LAN FS3*. Therefore, printers attached to this print server can be monitored in the same way as any other printers you want to monitor with KPM.

KPM can also be used to configure Kyocera printers.

19.2. Configuration Tips

Figure 17. Main screen of the KPM program

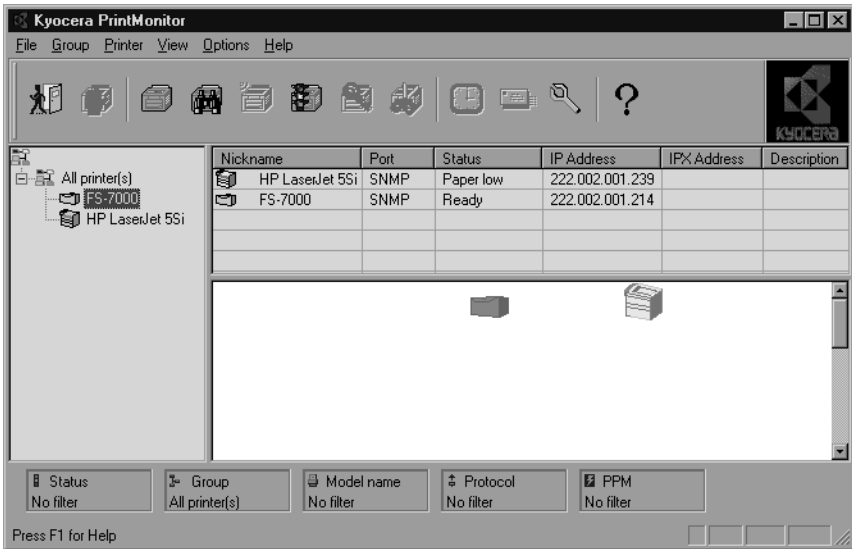

The PC running the program should be on the same LAN segment as the printer to be monitored. If this is not the case, another segment can be chosen by selecting Options > KPM Settings and clicking the *Discover Mode* tab (shown on the next figure)

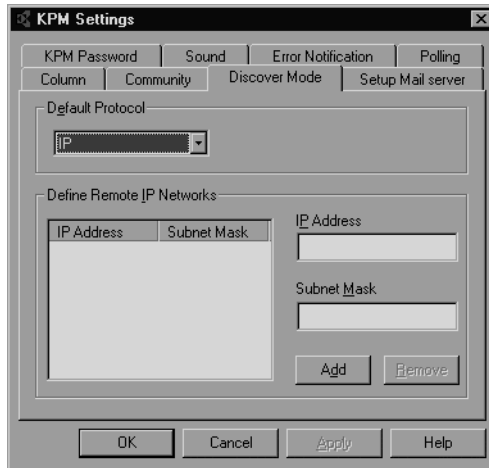
Figure 18. KPM Settings dialog box

The *Polling Time* should also be checked. This is done by clicking the *Polling* fan.

Further configuration of the program is described in the program's help section.

20. Printer and Job Status via "Finger" (External Tool)

20.1. Purposes and Limitations

With the TCP/IP Finger command you can get the following information for the system target printer:

- Interface Type (that is, type of print server)
- Firmware Version
- Name ("Host Name" (page 58), not "Device Name" (page 60))
- Printer Type
- Printer Job Status (up to three queued jobs)
- Printer Status

NDO users must remember that the system target printer can either be the local printer or a network destination.

The TCP/IP Finger command is supported on Windows NT / Windows 2000 / Windows XP (as a DOS command) and Unix systems.

In order to use it, you must be able to ping the *Intermate LAN FS3*.

If you cannot ping it, you probably need to establish a static IP route between the management PC and the print server.

20.2. How to Use It

Syntax

```
finger @<IP address>
```

Example (where the system target printer is on 192.168.1.188)

Command:

```
finger @192.168.0.227
```

Reply:

```
[192.168.0.227]
```

```
Interface Type : LAN FS3, Ver: K92_2011, Name: fs3a
```

```
Printer Type: LASERJET 4000
```

```
Printer Job Status: RAW Socket 0 192.168.1.188
```

```
Printer Status: Ready
```

Printer Job Status shows the first three jobs queued for printing; if there are none, the message is "No Job In Queue" .

Each job shows the print protocol and where the job originated (IP address).

If more than three jobs are queued the sequence ",..." is written after the third job.

UPGRADES AND MAINTENANCE

21. Upgrade Components

21.1. What and How

21.1.1. How to Get Upgrades

Regular firmware releases are made including new features and correction of errors. New firmware releases are made available on our web site. Partners are notified by e-mail when there are new releases.

21.1.2. How to See Which Firmware is Currently Loaded

The version numbers of the firmware currently loaded in the print server can be seen in the following status information:

- *Main Status Pages* (print-out from HTTP menu or from the TEST button - see [“Information from LEDs and from the TEST Button”](#) (page 166))
- *Code Revisions* (HTTP menu: “Status” > [Code Revisions], displayed on screen only).

21.2. What the Firmware File Names Mean

21.2.1. Version-Naming System

Example: Firmware component K92_1491.

The first 3 positions indicate the firmware Component ID. In this case it is a *Main Code* firmware (K92) for the *Intermate LAN FS3*.

The first digit after the underscore is the year of the release (2001).

The next two digits give the week number (**49**) and the last is the release level (build) within the week (**1**).

After testing and documentation are finished, the firmware is publicly released, so the public release date is often at least a week later than the week number in the firmware name and the date displayed in “Status > Code Revisions”.

21.2.2. Overview of Component Types and File Names

We provide the following component types:

- Boot Firmware

Boot Code enables the reception of firmware. The Boot Code is rarely upgraded. A faulty upgrade could cause the unit to lock, in which case it would have to be re-initialized. Contact your point of purchase if this happens.

- Main Firmware and API codes
- Fonts for Host Print Options (SCS and IPDS)

The firmware file names, as they appear on the web site, are shown in the first column in the tables below. Upgrade methods are also mentioned, while instructions on how to use a given method are found in the three chapters following this one. Note that the *IMCU* can be used to update several print servers at once (see [“Bulk Upgrade” \(page 152\)](#)) - provided that all the servers involved are based on the same software component and that they all have the same password.

21.3. "FSS-Files"

Boot Code and Main Code are upgraded via FTP directly, via FTP initiated and controlled by the *IMCU*, or via the *Intermate Download Utility* in conjunction with a serial upgrade cable. Note that the *IMCU* can be used to update several print servers at once.

File Name	Files Included	
K91-xxxx.zip	K91-xxxx.ffs	The <i>Boot Code</i> for the <i>Intermate LAN FS3</i> .
K92-xxxx.zip	K92-xxxx.ffs	The <i>Main Code</i> for the <i>Intermate LAN FS3</i> .
K65-xxxx.zip	K65-xxxx.ffs	The <i>IPDS API Code</i> . This code is downloaded to the printer at power up when IPDS printing is enabled.

HPO Fonts are upgraded via FTP directly, or via FTP initiated and controlled by the *IMCU*. Note that the *IMCU* can be used to update several print servers at once.

File Name	Files Included	
K66-xxxx.zip	K66-xxxx.ffs	The <i>SCS Fonts for TN5250E</i> used in connection with SCS/DCA printing from AS/400.
F08-xxxx.zip	font240.ffs	The <i>IPDS Font Files</i> bitmap fonts, 240 dpi fonts.
F09-xxxx.zip	font300.ffs	The <i>IPDS Font Files</i> bitmap fonts. 300 dpi fonts.
Note: There is only room for one set of IPDS fonts at a time; the unit is delivered with 300 dpi.		

21.4. Configuration Files

Factory default settings are written into a database where they cannot be affected by what you do as a user.

The FTP directory in the print server holds at least one, and sometimes up to 10 different FTP-"files" reflecting the current settings for the server.

21.4.1. "The" configuration file: ima_cfg.bin

The FTP file that is always present is `ima_cfg.bin`.

This file contains all current settings except print-server-specific identifying information (IP address, host name, and the like) and the "IDB" settings described below ([page 138](#)).

When your print server is factory new, `ima_cfg.bin` contains only factory defaults. Each time you save your own settings, they will replace the original values in `ima_cfg.bin`. And each time you restore factory defaults, the original values replace your own values in `ima_cfg.bin`.

You can use transfer the settings in `ima_cfg.bin` from one print server to another or to several others. This means that you can make a single configuration and then quickly set up several identically configured print servers.

As with all other operations involving the print server's FTP directory, you can use FTP directly (see "[The Binary Configuration File \(ima_config.bin\)](#)" ([page 144](#))) or use the *IMCU* (see "[Using the IMCU for Maintenance](#)" ([page 146](#))) and especially [Figure](#) on [page 150](#)). Note also that the *IMCU* can be used to update several print servers at simultaneously (see "[Bulk Upgrade](#)" ([page 152](#))) - provided that all the servers involved are based on the same software component and that they all have the same password.

21.4.2. .IDB

The IBM Host Print Options for SCS/TNe operate with collections of settings known as “IDBs”.

At any one time, the print server’s FTP directory can hold one TN3270e IDB and up to 8 TN5250e IDBs.

And again, you can use FTP directly or use the *IMCU*. Note that the *IMCU* can be used to update several print servers at once - provided that all the servers involved are based on the same software component and that they all have the same password.

For detailed information on TN5250E, see the Printing Environment Guide for IBM OS/400 Systems.

For detailed information on TN3270E, see the Printing Environment Guide for IBM Main-frame Hosts or the equivalent sections in the LAN FS3 10/100 Ethernet User’s Guide (KL008-02).

21.5. The Print Server's FTP Directory and Its Libraries

In connection with various kinds of upgrading, it is important to know what structure of the FTP Directory is.

In the list below, only the libraries which could be important for you to know about are shown, and a colon separates the library name from the file name(s). The versions indicated reflect the newest available in February 2002.

- BOOT: K91_1071.FFS
- MAINCODE: K92_2011.FFS
- TN3270IDB: (one IDB file if TN3270E is activated)
- TN5250IDB: (one or more IDB files if TN5250 is activated)
- IPDSFONT: FONT300.FFS (There are two alternative IPDS font files: FONT300.FFS and FONT240.FFS. A version number is not a part of the component name)
- TN5250FONT: K66-0151.FFS
- QUICKGUIDE: QGUIDE.TXT (A version number is not part of the file name)
- IPDS: K65_0441.FFS
- REBOOT: holds two files.
One called "controlled", the other called "immediate".
- CONFIG: ima_cfg.bin

21.6. How to Inspect the FTP Directory

- 1 Start an FTP session on the print server (sample IP address):
`ftp 192.168.0.227`
- 2 You will be asked to give your user name (admin) and the password (case-sensitive).
- 3 Change to the correct library.
`cd <libraryname>`
- 4 List the library contents.
`dir`
- 5 If you want to see another library, move up to the root again
`cd ..`
and repeat steps 3 and 4.
- 6 Close the FTP session.
`bye`

22. Using FTP Directly

22.1. Upgrades of Firmware and Fonts (FFS files)

- 1 Download the firmware file from the Intermate web site.
As our **example**, let us take the main code `K92_2011.zip`.

Note: You will need a decompressing tool based on the ZIP algorithm (for example WinZip®).

- 2 A single left click on the file name will bring up a File Download dialog box asking whether you want to open the file or save it.

When you open it (directly or after having saved it), you can then extract `K92_2011.ffs` to an accessible place on your PC or other host. This could, for example, be `C:\PrintServerUpdates`.

- 3 Start an FTP session to your *Intermate LAN FS3*.
`ftp 192.168.0.227`
- 4 Give the user name and password for the print server.
- 5 Change to the library containing the firmware component to be upgraded. To fit our example, you would do this:
`cd Maincode`

Important:

Be sure to select the correct library. Storing the wrong type of file in the wrong place can cause the system to lock.

- 6 Select binary transfer mode.
`binary`
- 7 Download the file from your PC to the print server. The syntax is:
`put <source> <target>`

The file name in the <source> part of the command must match the case of the file name on your PC.

The file must have the same name when it is "put" on the target, so prevent typographical errors by not specifying a name for the <target>.

Example:

```
put C:\PrintServerUpdates\K92_2001.FFS
```

- 8 Wait for the file transfer to complete. During file transfer, the Activity LED (yellow-orange) will flash; when the transfer is complete, it will turn off.
- 9 If you have more upgrading to do, repeat steps 5 - 8.

Important:

Before attempting to move to a new directory, you must first go up to the root again

```
cd ..
```

- 10 If you want to activate the settings from the HTTP menu, close the FTP session
bye

Otherwise, activate the new settings from within the FTP session.

cd ..	Move one directory level up
cd \reboot	Change to the "reboot" directory
get immediate	Perform an immediate reboot or
get controlled	perform a controlled reboot

The FTP session is automatically terminated.

Rebooting will take longer than usual because the flash memory is being programmed. While this is happening, both LEDs are lit. When both LEDs go out briefly, the programming is done. The print server should then return to "Ready" in the normal operation mode: the green LED (Activity) on and the orange-yellow LED (Link) off.

22.2. Upgrades of IDBs

If the file you want to load from our web-site is a so-called IDB file, right-click on the file name and choosing “save object” to place the file on an accessible drive. This replaces steps 1 and 2 above.

When you get to step 7, you can choose another name for the <target> than that in the <source>, and in this case, of course, both names must be included in the “put” statement.

Be careful about naming; please consult the Printing Environment Guide for your IBM OS/400 System or IBM Mainframe. This is also where you will find information on managing your own IDBs.

22.3. The Binary Configuration File (ima_config.bin)

The binary configuration file is located in the CONFIG library. The file name is `ima_cfg.bin`.

You will only want to work directly with this configuration file if you have made settings in one print server that you want to transfer to another. Therefore, you must first retrieve the file and save it on an accessible drive; then you can load the file from this drive to the PDF directory of another print server. The name of the drive and library you use could, for example, be `C:\PrintServerConfigs`.

When a configuration file is retrieved, the settings activated on the last reboot or start-up are copied. Changes made after a reboot are not contained in the file.

In the example below, we will take the configurations from the print server at 192.168.0.227 and transfer them to another print server at 192.168.0.170.

To retrieve

- 1 Start an FTP session to the print server whose configurations you want to transfer.
`ftp 192.168.0.277`
- 2 Change to the CONFIG library.
`cd Config`
- 3 Change to binary transfer mode.
`binary`
- 4 Retrieve the binary configuration file.
Syntax: `get <source> <target>`.

The file name in the `<source>` part of the command must match the case of the file name in the FTP directory.

Example:

```
get ima_cfg.bin  
c:\PrintServerConfigs\ima_cfg.bin
```

- 5 Terminate the FTP session.
`bye`

To store (load) to the print server

- 1 Start an FTP session to the print server you want to transfer settings to
`ftp 192.168.0.170`
- 2 Give the user name and password for the print server.
- 3 Change to the CONFIG library.
`cd Config`
- 4 Change to binary transfer mode.
`binary`
- 5 Store the binary configuration file

Syntax: `put <source> <target>`.

The file name in the <source> part of the command must match the case of the file name on your PC.

The file must have the same name when it is "put" on the target, so prevent typographical errors by not specifying a name for the <target>.

Example:

```
put C:\PrintServerConfigs\ima_cfg.bin
```

- 6 Continue as described in steps [8](#) - [10](#) on [page 142](#).

23. Using the *IMCU* for Maintenance

23.1. Advantages





The *IMCU* has three great advantages when working with one print server at a time:

- It allows you to incorporate the process of checking for and downloading new firmware versions in to your loading procedure.
- It initiates and controls an FTP session and saves you from having to know library and file names in the print server's FTP directory. (However, in order to find appropriate information in the documentation, you still need to be aware of the different file types as listed on [page 148](#).)
- It allows you to transfer settings directly from one print server to another (see [page 150](#)).

The *IMCU* also makes it possible to do bulk upgrades, that is to update several print servers simultaneously. This assumes that all the print servers you want to include in a bulk upgrade have the same password.

Note: You must use Internet Explorer 4.01 or later to be able to upload a file from your local computer. Any version of Netscape should work also, but this has not been thoroughly tested.

23.2. Single Print Server

- 1 Log in to the *IMCU* server program.
- 2 Display the “Device list”. 
- 3 Use the “Expand” icon to bring forth a list of devices discovered on the segment where the print server you want to update or transfer settings to is located. 
- 4 Make sure that you have the “Links” column displayed. If there are many columns displayed, you may have to scroll to the right to find it. If it’s not there you need to adjust your column selection. 
- 5 Refresh the information on the segment. 
- 6 Locate the *Intermate LAN FS3* to be upgraded.
- 7 Find the “firmware upgrade” icon in the “Links” column. Clicking on it will bring up a list as shown below in the next step. 

8

Select type of firmware to upgrade:

- Main Code
- Boot Code
- IPDS Code
- IPDS Font
- SCS Font
- TN3270E IDB
- TN5250E IDB
- Configuration

Mark the types of files to be upgraded.

About file types

Main Code, Boot Code, IPDS Code and IPDS Font files, SCS Font files are FFS files. See [“Upgrades of Firmware and Fonts \(FFS files\)”](#) (page 141).

The two kinds of IDBs are briefly described in [“Rebooting will take longer than usual because the flash memory is being programmed. While this is happening, both LEDs are lit. When both LEDs go out briefly, the programming is done. The print server should then return to “Ready” in the normal operation mode: the green LED \(Activity\) on and the orange-yellow LED \(Link\) off.”](#) (page 142), which also refers you to where you can get detailed information appropriate to your IBM host environment (OS/400 systems or Mainframe).

“Configuration” refers to your own configurations as described in [“The Binary Configuration File \(ima_config.bin\)”](#) (page 144).

- 9 Finish by clicking [Next].
- 10 For each file type you have selected, the *IMCU* will ask you for the physical location of the desired file in the LAN environment. The examples below illustrate two file types.

FFS files, such as "Main Code

Select Main Code file (K92* FFS) for Intermate LAN FS3 10/100:

Select from the following list of files located on the IMCU server:

K92_2011.FFS

Or select a file on your local computer:

Filename

If you would like to download the latest firmware files, visit [Intermate's LAN FS3](#)

If you have previously upgraded a device of this type, the *IMCU* server will keep the FFS file(s) in a folder called "Firmware", located in the library where the *IMCU* server has been installed. See the radio button on the top half of the screen shot above

If you want to select a different file you must select it from the local computer.

If you haven't already saved the file you want to use on an accessible drive, you can use the link provided to the product web site. Find the file you want and save it (see [page 136](#) if you need help to do this). Then return to the "select" dialog and type in the file name (full path), or use the "Browse..." button.

Configuration file

Select Configuration file (*.BIN):

Select a file on your local computer:

Filename

Or enter the IP address of an interface to copy the configuration file from:

If you choose to select a file on your local computer, you must first have retrieved it from the source; see [“To retrieve” \(page 144\)](#) in the chapter on upgrading directly with FTP.

Finish each file selection with “Next >”.

- 11 Repeat the process of selection for each type of file you have checked.
- 12 The final “Next>” in connection with file selection will bring you to a dialog in which you must specify the user name and password for the server in question.
- 13 You will then be asked whether or not you want the *IMCU* to reboot your *Intermate LAN FS3* after the upgrade.

If you are absolutely sure that there are no current print jobs which can be ruined by an “immediate reboot”, it is safe to answer yes.

If not, you must remember to do a “controlled reboot” afterwards, directly from the print server.

- 14 When you click “Next>” again, the updating will start.
- 15 The process is usually very fast, but if you get impatient, be careful not to switch off the print server, or shut down the *IMCU* server (by closing the browser) during the upgrade.

If you want to do other things with your browser while waiting for the update, you can either open a new instance or continue in the same instance by typing a new URL in the address box. If you continue in the same instance, you can use the browser's "back" and "forward" arrows to move among the different things you have running.

23.3. Bulk Upgrade



When you are done with steps 1 - 5 as described starting on [page 147](#), click on the “Bulk Firmware Upgrade” icon, located in the top row of icons.

Your click will bring up a dialog like this:

Select devices to upgrade:

Agent	Devices		
2.1 net on DIK2 			
5.4 net <input checked="" type="checkbox"/> ✓ %	Upgrade	Printer type	Interface firmware
	<input type="checkbox"/>	[Unavailable]	G32_2041
	<input type="checkbox"/>	LASERJET 4000	G32_2041
<input type="checkbox"/>	FS-3800	K92_2011/K65_04	
IMPRINTSERVER 2.1 and 2.2 ✓ %	Upgrade	Printer type	Interface firmware
	<input type="checkbox"/>	Lexmark T620	3.17.4
	<input type="checkbox"/>	[Unavailable]	G32_2041

View log Next >

Note the following things about this dialog.

The devices displayed are only those with firmware that the *IMCU* is able to recognize and put the files in the correct library in the FTP directory.

Use the “upgrade” check box to select a device for upgrading.

- ✓ You can use the check mark to select all the devices listed by a given agent segment. But do so only if they all are the same type of print server (interface firmware component, such as G32 or K92) and all have the same password.
- ✗ This (European) minus sign deselects all the devices listed by a given agent segment.

When you continue with “Next”, the procedure is the same as described for upgrading single servers, starting with [step 10 on page 149](#).

24. Upgrade of Main Code or Boot Code Using a Serial Cable

This approach can only be used with FFS files.

To use it, you need a suitable cable and the *Intermate Download Utility Program* (p16-xxxx).

24.1. The Cable

Files are downloaded via an DB9-PS/2upgrade cable (described in the *Product Overview*) to the serial I/O port (console port) built in to the PS/2 connector on the *Intermate LAN FS3*.

24.2. The Intermate Download Utility Program

This is a free program included on the CD and also available from our web-site. The program is a native 32 bit Windows95/98/NT4.0 application. It is installed by executing the file *P16-xxxx.exe*.

When the *Download Utility* is used for the first time the *Communication Port* (COM port) and *Baud Rate* settings should be checked. The COM port is the PC port the upgrade cable is plugged into. The Baud Rate may vary depending on the PC. Usually a rate of 19.200 bps is good.

Files must first be saved on an accessible drive on a PC (see [“Upgrades of Firmware and Fonts \(FFS files\)” \(page 141\)](#)).

Files are downloaded by connecting the PC running the utility to the printer via the serial upgrade cable.

The printer must be powered Off before it is connected to the PC.

Do NOT power it On until asked to by the *Download Utility*.

The Download menu is activated from the keyboard <Alt+d>. Select the file as always in a Windows program.

Click on the “Open” button to initiate the download and follow along with what happens on the screen.

When you are asked to power On, you must first press the “TEST” button and keep holding it while powering On. This is necessary in order for the unit to enter “Download” mode.

The Activity LED is ON and the Link LED is OFF when the *Intermate LAN FS3* is in “Download” mode.

On reboot, both LEDs light during programming of the Flash memory. When both LEDs go out briefly, the programming is done. The print server should then return to “Ready” in the normal operation mode: the green LED (Activity) should be on and the orange-yellow LED (Link) should be off.

Refer to the *Intermate Download Utility* program's on-line help pages for further detail. These are accessed via the help menu (<Alt+h>).

25. Overview of Types of Resets

25.1. Activate New, Saved Settings with a Reboot

To activate any new setting, the unit must be rebooted.

Rebooting resets the information in the System Log. So you may want to print out the Main Status Pages before rebooting.

There are two kinds of normal reboots: “immediate” and “controlled”.

- “Reboot (immediate)” reboots the *Intermate LAN FS3* immediately, terminating any current print job and. Jobs queued after a terminated job are not affected.
- “Reboot (controlled)” performs a delayed reboot. A reboot command is added to the job queue. The reboot is carried out when there are no more jobs known to the *Intermate LAN FS3*.

Both types of reboot can be achieved remotely through HTTP-menu, a Telnet client or an FTP session.

When you load firmware, fonts, etc. using the IMCU, you can also use the IMCU to perform an Immediate remote reboot.

Finally, can do a hardware reboot, which is useful in certain situations (for example those described in “[Restore Factory Defaults: TEST Button](#)” (page 158)). Hardware reboots can be done by turning the printer Off and then On. It is best to wait about 10 seconds from the last saving until you power Off.

After a reboot, it takes up to 30 seconds before the print server is Ready.

25.2. Restore Factory Default Settings: Remote

HTTP Menu: Configuration Page Only

On each configuration page, there is a “Factory Default” button. This will reset all the parameters on the page, and only on that page.

Reboot to activate the change.

HTTP Menu: “Restore All Defaults”

This is something very rarely done.

This menu item is in the “Actions” group on the left menu.

“All Defaults” includes both the contents of the configuration file and specific identifying information (such as IP address, host name, and license key).

Note for users of SCS TN5250E and SCS TN3270E:

Included in the configuration file is the association of a given IDB name and a session but not the “IDB” settings themselves.

Reboot to activate the change.

If you have problems doing a total reboot remotely, use the TEST Button instead.

Telnet Client:

Restoring factory defaults is not possible using Telnet.

25.3. Restore Factory Defaults: TEST Button

General Information

You can do two types of resets. The difference between them depends on how long you hold the Test Button before letting go.

Use a pointed object to press the Test Button in. If you are not good at counting seconds, you should make sure you can see a watch or clock that shows seconds.

Caution:

Resetting requires the printer engine to be warm.

If the engine is cold, you should power the printer On and wait for it to report *Ready*. When it does, you can power it Off and perform the reset operation you wish.

- a Turn the printer off.
- b Press the TEST Button.
- c Turn the printer On while you keep holding the Button for:

number of seconds:	Result
less than 31 sec.	Reset IP address to 0.0.0.0, subnet mask to 255.255.255.0 and default gateway to 0.0.0.0
more than 41 sec.	Restore All Defaults. This is just like the remote "Restore All Defaults".

- d When you let go of the Button, a confirmation page will be printed if the reset has been successful.
- e Reboot. A hardware reboot is easiest— power the printer Off and then On.

APPENDICES

Appendix A. Customer Support

A.1. Where to Find Support

LCI Intermate A/S provides full technical support for this product. Contact information is found on the title page of this guide - as well as on HTTP menu and on every print out of the *Main Status Pages*.

If you encounter problems, or have questions on how to use the *Intermate LAN FS3*, however, please start by contacting your point of purchase.

A.2. Gathering Information

Always include the following steps when you start to troubleshoot:

- 1 Print out the *Main Status Pages* for the *Intermate LAN FS3*. The *Main Status Pages* will show error messages and/or warnings, corresponding to the information which is displayed on screen by choosing "Status"> [System Log].
- 2 You may also want to print out the printer's status pages; refer to your printer documentation. This is especially relevant for users of the *Intermate LAN FS3*.
- 3 Note the release levels of both the firmware, main software, LAN boot code and the printer's firmware. Check our website to see if there are updates.
- 4 Update everything you can, and then try again.

If you need to seek specialist help, make as complete a description of the error situation as possible. A special area of interest is whether the error can be provoked and reproduced, or if it is occurring randomly. In addition, you should describe the environment as precisely as you can. This involves the configuration description of the TCP/IP, servers, printers, LAN type, etc.

Appendix B. Technical Information

B.1. Hardware

Figure 1. What the Back Panel Looks Like

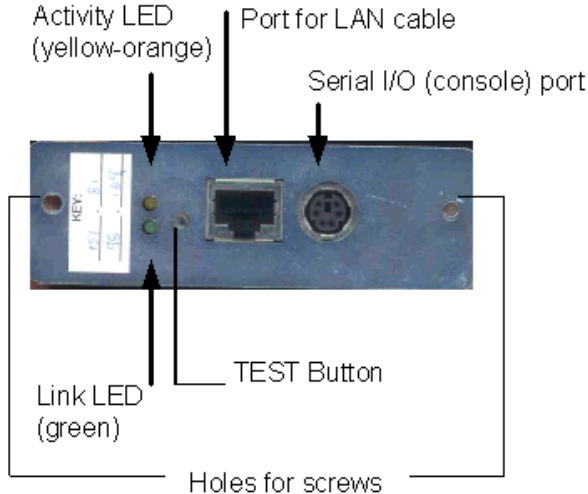

Port for Ethernet LAN cable: This is an RJ-45 connector including auto detection of 10BaseT and 100BaseTX. In units sold before 4 January 2002 (up to and including K92_1491) there is also auto detection of Ethernet II, IEEE802.2, IEEE 802.3 and SNAP frames.

Serial I/O (console) port: PS/2.

You will need a LAN drop cable, which is **not** included.

Complete information on the LED Patterns and TEST Button is in the appendix [“Information from LEDs and from the TEST Button”](#) (page 166).

B.2. Supported Printers and Performance Features

Monochrome printers:

FS-600
FS-680
FS-800
FS-1000
FS-1200
FS-1700+
FS-1750
FS-1800
FS-3700+
FS-3750
FS-3800
FS-6700
FS-6900
FS-7000
FS-7000+
FS-9000

Color Printers:

FS-5800 C
FS-5900C
FS-8000C

Digital Copiers:

KM-4230
KM-5230
KM-6230

- and any other Kyocera-Mita printers or copiers which are sold from an authorized dealer with the *Intermate LAN FS3* already installed. Always be sure to use the newest available firmware.

IPDS printing is only available in the monochrome printers. For IPDS printing, a printer must have at least 12 MB RAM and in many cases, 16MB is advisable.

The performance-related features of the hardware are as follows:

- MCF 5206e RISC Processor with 23 MIPS performance
- 2 Mbyte DRAM
- 2 Mbyte Flash memory for micro-code.
- Support for both 3.3 v and 5v KUIO port technologies.

If you purchase and enable the Network Destination Option (NDO), up to four network printers— attached to the LAN with any kind of print server you wish—can be made known to the *Intermate LAN FS3*, thus making the facilities of one multi-protocol print server available to up to five different printers.

The *Intermate LAN FS3* retrieves printer status information from a network printer through SNMP. For this to function properly, a network target printer must support the status information nodes defined in the Printer MIB (RFC1759) and some host information nodes of the Host Resources MIB (RFC1518).

B.3. Emission Notices and Approvals

USA: FCC Rules Part 15, Class A

This equipment generates, uses, and can radiate radio frequency energy and if not installed and used in accordance with the instruction manual, may cause interference to radio communications.

It has been tested and found to comply with the limits for a Class A computing device pursuant to Subpart B of Part 15 of FCC rules, which are designed to provide reasonable protection against such interference when operated in a commercial environment.

Operation of this equipment in a residential area is likely to cause interference in which case the user at his own expense will be required to take whatever measures may be required to correct the interference.

Shielded cables should be used with this unit to ensure compliance with the Class A limits.

EU: EMC, CE Declaration of Conformity

 This product complies with the harmonized standards for EN55022: 1998 Class B and EN55024; 1998.

Appendix C. Hardware Installation

You need a screwdriver to perform the installation.

If the printer is going to be used for IPDS printing and needs extra printer memory, please install this extra memory before installing the LAN FS3 in the printer.

Discharge yourself from static electricity before unpacking or otherwise handling the unit. Do this by touching an unpainted part of the printer's metal cabinet. Alternatively, you can wear an anti-static wrist strap.



1 Power Off the printer.

If the printer is not powered Off before the installation, parts of the print server or the printer may be permanently damaged.

- 2** Remove the metal plate covering the KUIO port by taking out the screws with a screwdriver. Refer to your printer documentation.
- 3** Remove any interface or cable occupying the internal KUIO port you wish to install the unit in.

Be sure to check that this is OK with the network administrator.

- 4** Slide the card into the internal KUIO port. Secure its position with the screws.
- 5** Insert a LAN drop cable from your LAN in to the print server.
- 6** Power On the printer. It is usually a good idea to document current settings and save the pages for reference. If you wish to do this, wait until the printer reports **Ready** (the print server should have only one LED lit: the green one). Then press the **TEST** Button for 1 or 2 seconds. This will print the *Main Status Pages* for the unit.

Appendix D. Information from LEDs and from the TEST Button

Refer to [“What the Back Panel Looks Like” \(page 161\)](#) to see the location of the LEDs and the TEST Button.

D.1. LED Patterns in Various Modes

Basic Operation:

Upper LED is yellow-orange - “Activity”.

It is lit when data is received and turned off when no data is present.

Bottom LED is green - “Link”.

It is lit when the print server has established a link with the LAN. If the link is lost, the LED is turned off.

Power Up Mode:

Activity On & Link Off = Powering Up

Activity Off & Link On = Unit is Ready

Normal Operation Mode:

Activity Off & Link On = On-line with LAN

Activity Flashing & Link On = LAN traffic detected

Both Off = no LAN detected / off-line

Download Mode with Intermate Download Utility & Serial Cable:

Activity On & Link Off

Download Mode via FTP or FTP controlled by the IMCU:

Activity Flashing & Link On

“Programming Flash Memory”:

This mode occurs during the first reboot after download of new firmware, file, etc.

Both On = programming in progress.

Both Off very briefly = programming finished.

Then the print server returns to normal operation mode,
Ready: Activity Off & Link On.

D.2. TEST Button to Print *Main Status Pages* or *Quick Guide*

The TEST button is located on the side of the unit. It is operated with a pen or similar pointed object.

When you want to print information using the TEST button, you must make sure that the LED display shows the green light, and only the green light, which indicates that the Unit is Ready.

Pressed while operational ("Ready")	Result
Press & hold 1-2 seconds for less than 4 seconds	Print <i>Main Status Pages</i> (shortened to <i>Status Pages</i> on the label).
Press & hold for at least 4 sec.	Print on-board <i>Quick Guide</i>

The *Main Status Pages* describe all current configurations, firmware level and the content of the System Log (errors, etc).since the last reboot.

The same *Main Status Pages* can also be printed from the HTTP menu by choosing [Print Main Status Pages] from the "Action" group.

The *Quick Guide* is a mini-manual meant to help you if it is not convenient or possible to use the complete documentation.

The *Quick Guide* can also be printed from the HTTP menu by choosing [Quick Guide] in the "Help" group.

Appendix E. ASCII 7-bit Character Set: Decimal Values 32 - 126

This table is an extract of the 7-bit ASCII character set. For each decimal value 32 - 126 inclusive, the Hex values and ASCII character are shown. The characters produced by lightly shaded values (32 and 123-126 decimal) are not quite as universal as is the case with the others in the table.

Each group of three columns is to be read downward through two pages.

Decimal	Hex	ASCII	Decimal	Hex	ASCII	Decimal	Hex	ASCII
32	20	space	64	40	@	96	60	"
33	21	!	65	41	A	97	61	a
34	22	"	66	42	B	98	62	b
35	23	#	67	43	C	99	63	c
36	24	\$	68	44	D	100	64	d
37	25	%	69	45	E	101	65	e
38	26	&	70	46	F	102	66	f
39	27	'	71	47	G	103	67	g
40	28	(72	48	H	104	68	h
41	29)	73	49	I	105	69	i
42	2A	*	74	4A	J	106	6A	j
43	2B	+	75	4B	K	107	6B	k
44	2C	,	76	4C	L	108	6C	l
45	2D	-	77	4D	M	109	6D	m
46	2E	.	78	4E	N	110	6E	n
47	2F	/	79	4F	O	111	6F	o

Decimal	Hex	ASCII	Decimal	Hex	ASCII	Decimal	Hex	ASCII
48	30	0	80	50	P	112	70	p
49	31	1	81	51	Q	113	71	q
50	32	2	82	52	R	114	72	r
51	33	3	83	53	S	115	73	s
52	34	4	84	54	T	116	74	t
53	35	5	85	55	U	117	75	u
54	36	6	86	56	V	118	76	v
55	37	7	87	57	W	119	77	w
56	38	8	88	58	X	120	78	x
57	39	9	89	59	Y	121	79	y
58	3A	:	90	5A	Z	122	7A	z
59	3B	;	91	5B	[123	7B	{
60	3C	<	92	5C	\	124	7C	
61	3D	=	93	5D]	125	7D	}
62	3E	>	94	5E	^	126	7E	~
63	3F	?	95	5F	_			

Appendix F. String Syntax

F.1. Basic Rules and Encoded Bytes

A string can consist of both character strings and other elements.

Character strings consist of printable characters, all of which are treated as case-sensitive. The phrase “printable characters” means all characters within the decimal range 32 - 126 or hexadecimal /20 - /7E; see [“ASCII 7-bit Character Set: Decimal Values 32 - 126” \(page 169\)](#). Character strings are enclosed within quotes, e.g. “This is a string”.

If you write your strings in Kyocera Prescribe, all characters will be printable, so you only need to remember to enclose the commands in quotes. If you write your strings in HP PCL or similar printer control language, you will also need to use other elements written directly in hex or decimal notation. By “other elements” is meant characters outside of the permissible range for inclusion in character strings. In order to enter these characters, you must type in the decimal or hexadecimal values directly.

- Decimal numbers are written without any special indicators, e.g. write 65 as 65. The allowable decimal range is 0 - 255.
- Hexadecimal numbers must be preceded by a slash, e.g. /1B. The allowable hexadecimal range is /00 - /FF.

The characters you type in are not all encoded in the flash memory. For example, assume that you have some reason to represent the letter B in hexadecimal, you would type in the string /42. This encodes to B and fills only 1 Byte of flash space; in other words it only fills 1 Encoded Byte.

When you mix elements in a given string entry, you must separate them with commas. The string "A", /42, "C" encodes to ABC and fills 3 Encoded Bytes.

If an element separator within the command sequence is ille-

gal, the whole string is considered invalid and ignored. The next section gives examples of valid and invalid strings.

Note: A pair of double quotes "" cannot be written as a normal string, i.e. within quotes. They have to be written with their decimal or hexadecimal number: 34, 34 or /22, /22.

F.2. Examples of Valid Strings and Invalid Strings

Valid Strings	Valid Strings (continued)
"abc", /41	65, /41
"abc", 65, /41	/41, 65
"abc", "def"	/41, /1B, "a"
"abcdef"	/41, /1b, "a"
"abc", 65, 66, 32, /1B, /1B, "def"	" /1B, 65, abc, def, 127"
27, 65	/1B, 34, /65

Invalid Strings	Why
abc, 65	- quotes are missing around "abc"
/41, abc	- quotes are missing around "abc"
/41abc	- a comma is left out and quotes are missing
65, "abc" /1B	- a comma is left out
"abcdef", /1B, 65, "ahg"	- end-quote is missing
"abc", /1B, 65	- whole string could be considered a string, but isn't because the end-quote is missing
1B, 65	- slash before hexadecimal number is missing
65, 66, ab"	- start-quote is missing
/1B, , 65	- two consecutive commas

Appendix G. Configuration Checklists

G.1. Overall Checklist

- 1 Establish contact.
Assign IP address, subnet mask, default gateway.
- 2 Login. The default password is admin and the password is admin.
- 3 Configure the remaining parameters in [TCP/IP] configuration:
 - Host name is mandatory. Check the syntax guidelines.
 - DNS server is where the *Intermate LAN FS3* does look-ups
if you enter names instead of IP addresses for various servers and hosts in other configurations.
 - Registering a WINS server makes your *Intermate LAN FS3* known to an NT environment.
- 4 Configure the [General] settings and [Network] settings.
- 5 Change the password.
- 6 Enter your license key if you have purchased one or more of the available options: Network Destination Option (NDO); Host Print Option (SCS TNe and/or IPDS).
If your point-of-purchase has already installed a Software Key, it will be written on the label on the back of the unit.
If you get a key yourself, we recommend that you write it on the label.
- 7 Configure one or more target printers (physical printers)
 - Configure the local printer; this is the printer to which the *Intermate LAN FS3* is directly attached.
 - If you have the NDO, configure up to four network printers.
- 8 Configure logical printers as needed (see below, step [3](#), [page 175](#)).

- 9 If you wish, configure one or more status monitoring aids. You can choose from among e-mail, notification, SNMP and enabling of the embedded *IMCU* agent.
- 10 Configure the services you want to use from among the following possibilities—and use the [“Checklist for Each Service or Host Session”](#) (page 175) for each:
 - IPP (Internet Printing Protocol)
 - Raw Socket TCP Port (up to 4)
 - LPR queue (up to 8 configurable queues; there are also 4 non-configurable queues)
 - FTP
 - IPDS
 - TN5250E (host-sessions - up to 4)
 - TN3270E (host-session)
- 11 Remember that it is necessary to reboot in order to activate new settings.
- 12 It is always a good idea to document your configurations by printing the *Main Status Pages*.

G.2. Checklist for Each Service or Host Session

Printer Definitions on the Host

For each service, you must configure one or more printer-definitions (often just called “printer”) on the host(s).

"Host" in this context should be understood as the origin of a print job sent to the *Intermate LAN FS3*.

You may need to cycle back and forth a few times to coordinate the settings on the *Intermate LAN FS3* with the host printer-definition(s).

Settings on the *Intermate LAN FS3*

Configuration is done on one or more configuration pages dedicated to the particular kind of service or host session. The details are different for each type of service. But the following things are common to all:

- 1 Each configuration page must be saved before leaving it.
- 2 No configuration pages are activated until you reboot. You will usually do and save several pages before rebooting.
- 3 Each service must know where to direct output.

This is done by choosing a value in the "Use logical printer" field. You can only choose a target printer via a logical printer. If you have the NDO, you must use logical printers to reach your network printers, even if you do not need the special data manipulation features in the configurable logical printers.

- 4 If the output is to be directed to one of the configurable logical printers, check the configuration page [Logical Printers 1-8] and make sure that the definition of your chosen logical printer does what you want it to:
 - Does it point to the target printer (Local Printer, single Network Printer / Network Destination or Load Balancing Pool) you want to be used for printing this kind of job?

- If the target is a load balancing pool, are the printers compatible with each other and are they listed in an appropriate order?
 - Are "string before" and/or "string after" (if any) correctly defined?
 - Are substitution string(s) (if any) correctly listed? And have they been properly entered in the [String Substitutions] configuration page?
- 5** Check to be sure the target printer is configured properly
- If the target printer chosen is a network printer, then find this printer under "Output Control" > [Network Printers (NDO)]. Check to see that the IP address (or name) is ok, that the marked print method (Raw Socket or LPR) works on the printer, and that the necessary information for the chosen print method is properly entered.
 - If the chosen target is a load balancing pool, then check to see that all of the printers in the pool are configured properly.
 - After rebooting, choose "Status" > [Target Printer Info] to do a last check of the network printers.